

OSHI

100% plant-based fish backed by Investors of Impossible Foods & Oatly



oshi.com Hackensack, NJ [in](#) [f](#) [@](#)

Technology Notable Angel B2B Food & Beverage Ecommerce

Highlights

VC-Backed

Raised \$250K or more from a venture firm

- 1 Successful pilot with 100+ restaurants; Next Level Burger, Veggie Grill, City Roots Hospitality etc.
- 2 1,000+ Direct to Consumer customers with 93% positive feedback
- 3 \$10M+ raised from VCs Unovis (Beyond Meat, Oatly), Alumni Ventures (Impossible Foods), and more
- 4 Vegpreneur's Best Product of 2025 & endorsed by Michelin-starred chefs
- 5 \$1M in revenue projected in 2026 across 686+ retail doors nationwide (not guaranteed)
- 6 Founded by a repeat founder, 3 PhDs, and board members from Oatly and Impossible Foods
- 7 Pioneering plant-based fish in a \$1.2B market; partnering with seafood manufacturing giant in Brazil
- 8 Patented modular layering tech creates whole cut flaky salmon; 18g protein + omega 3s

Featured Investors



Björn Öste
Syndicate Lead

Follow

Invested \$5,000

Co-Founder of Oatly, which scaled from a Swedish startup to a \$10B IPO and redefined the dairy aisle worldwide. A serial entrepreneur and food system activist with decades of experience turning plant-based ideas into global category leaders.

"I've spent decades building a category-defining company in plant-based foods, taking Oatly from a niche idea to a global leader by winning on taste, functionality, and brand. That experience has made me both optimistic about the category—and very skeptical of how hard it is to get right.

I first met Ofek Ron in 2022 and later that year tasted Oshi's earliest prototypes. To be honest, I initially tried to talk him out of it. Plant-based fish is an even tougher challenge than dairy, and very f..."

[Read More](#)



Pitango

Follow

Invested \$3,000,000 ⓘ

One of Israel's most established VC firms. \$3B+ AUM, 300+ investments, 100+ exits. They've backed category leaders before the world knew they were category leaders.



Unovis

Follow

Invested \$250,000 ⓘ

The alternative protein fund behind Beyond Meat and Oatly before they went public. On a mission to transform the global food system to one that is more sustainable from the perspectives of the environment, food scarcity, health, and animal protection.

"Seafood is one of the last frontiers in the alternative protein revolution. We've seen what plant-based can do to meat and dairy - Oshi is bringing that same disruption to salmon, the most consumed seafood in America. The science, the texture, the team: this is exactly the kind of company we built Unovis to back."



Nas Daily

Follow

Invested \$25,000 ⓘ

Global Creator & Entrepreneur

"I've traveled to 197 countries and eaten thousands of meals, and I can say that Oshi is making something remarkable! Plant-based fish that takes the seafood experience to the next level. But I don't just invest in a good product, I invest in a founder I believe in, and that's Ofek."



OurCrowd in

Follow

Invested \$1,000,000 ⓘ

Israel's most active venture investor for 11 consecutive years. \$2.3B+ in commitments, 480+ portfolio companies, and a global network of 240,000 investors across 195 countries.



Cardumen Capital

Follow

Invested \$1,500,000 ⓘ

A European-Israeli VC with a dedicated AgriFoodTech fund backing the next generation of food innovation. They invest in scientific breakthroughs with real-world impact — and Oshi is in their portfolio.

"We search for teams with the rare ability to solve hard problems that the rest of the world hasn't figured out yet. Oshi is a perfect example - taking one of the most complex proteins to replicate and cracking it with science and ingenuity. We back founders like this because they don't wait for the category to exist, they build it."



Eschar Ben-Shitrit

Follow

Invested \$3,000 ⓘ

Co-Founder & CEO of Redefine Meat -- the company pioneering 3D-printed whole-cut plant-based meat. He left a successful tech career to build a better food system. He knows category-defining food tech from the inside out.



Adi Daniel

Follow

Invested \$5,000 ⓘ

Co-Founder & CTO of Wazimo, the data-driven media tech company acquired by Minute Media for ~\$65M. A serial builder with a track record of turning technical innovation into exits.



Tal Lev-Ami

Follow

Invested \$10,000 ⓘ

Co-Founder & CTO of Cloudinary, the visual media platform trusted by thousands of the world's top brands. A PhD computer scientist who knows how to build category-defining technology at global scale.



Gil Hirsch

Follow

Invested \$5,000 ⓘ

Co-Founder of StreamElements (\$111M raised), powering millions of creators on Twitch and YouTube. Previously co-founded Face.com, acquired by Facebook. Serial entrepreneur and active angel investor.

Team



Ofek Ron Co-founder / CEO

Activist & 4x founder. Drove global business development at vegan certification non profit, raised \$19.5M and placed patented plant-based fish in retail. Reichman University Economics BA.



Dr. Sam Bernhardt CTO

R&D powerhouse. Managed nearly \$100M in annual sales across 19 global markets at SodaStream, launching 150+ SKUs. Led product development at plant-based startup Zero Egg. Hebrew University Biochemistry PhD. NYU MBA.



Moran Lahat Operations Director

Quality guardian. Former quality assurance specialist at Thuvia, Israel's largest food company, and Food Safety Manager at Aroma, Israel's largest café chain. Hebrew University Biochemistry and Food Science BS.



Tal Golan Chief of Staff

Commercialization expert with a decade of experience in plant-based seafood. Alt-protein enthusiast, and economics major.



Björn Öste Advisory Board Member

Plant-based evangelist and unicorn builder. Co-founded and grew Oatly into a \$10B global mega-brand and IPO. Founder of Good Idea Drinks. Sold DynaSoft to RSA Security. Linköping University Industrial Economics MS.



Eyal Briller Founding Board Member

CPG Maverick. Built product management at Impossible Foods from the ground up. Scaled Hero Bread from 23 to 2,300 stores in under 3 months. Technion BSc Biotechnology and Food Engineering. Stanford MBA.



Daniella Yamin Marketing / Post CD



Ofek Ron

Memo

100% PLANT-BASED FISH

BACKED by IMPOSSIBLE FOODS and OATLY INVESTORS

Oshi is on a mission to bring the first whole-cut 100% plant-based salmon fillet in the

Chains & Hospitality groups Retail pipeline

While operating in pilot mode, revenue grew 4x year-over-year without a retail footprint or national marketing push.

Next up: retail scale. We are preparing a national rollout targeting 686 retail doors in 2026, supported by distribution through KeHE and United Natural Foods, Inc., two of North America's largest natural and specialty food distributors.

EVEN SEAFOOD LOVERS ARE QUESTIONING FARM-RAISED SALMON

Americans consume nearly 1 billion pounds of salmon every year, but consumers are increasingly growing uncomfortable with how it's produced - for the oceans, the animals, and their own health.

WILD SALMON POPULATIONS HAVE **SHARPLY DECLINED** DUE TO OVERFISHING, HABITAT DESTRUCTION, POLLUTION, AND CLIMATE CHANGE.

As wild populations declined, industrial fish farming scaled to meet demand. Today, most salmon are farm-raised in crowded open-net pens in the ocean, where parasites and disease spread easily, and farms rely on pesticides and antibiotics to control outbreaks.

IN SOME REGIONS, FARM MORTALITY RATES HAVE RISEN FROM **~3% TO MORE THAN 13%**, WITH UP TO **15-20%** OF FISH DYING BEFORE HARVEST.

Farmed salmon can accumulate contaminants such as PCBs (polychlorinated biphenyls) - industrial chemicals that persist in the environment and build up in animals.





Despite these concerns, salmon prices have surged ~4x since the early 2000s.



And the alternatives fall short. Most plant-based seafood products are processed formats like nuggets or patties, failing to deliver the premium salmon experience people expect.

We are left with a strained seafood system and no true replacement for one of the world's most beloved proteins.

PATENTED WHOLE-CUT FILLETS THAT FLAKE AND TASTE LIKE THE REAL THING

Oshi's flagship product is the first whole-cut 100% plant-based salmon fillet in the US market, designed to deliver the look, texture, and flavor of real salmon. We approached fish the way Impossible approached beef – by reimagining it from the inside out.





Oshi is crafted with premium plant-based ingredients, including Omega-3s from algae, avocado oil instead of industrial seed oils, and mycoprotein, a fungi-derived protein that recreates the natural fibrous texture of fish.

Using our patented Modular Layering technology, we recreate the natural muscle structure of fish so the fillet flakes beautifully, sears properly, and cooks like premium salmon.

oshi SALMON

4.40Z PORTION

- 18G PROTEIN
- RICH IN OMEGA-3S
- GF AND NON-GMO
- MADE WITH SOY PROTEINS & MYCOPROTEINS
- EASY-TO-COOK





NO FISHY INGREDIENTS *EVER.*

- ✗ NO SEED OILS
- ✗ NO MERCURY
- ✗ NO ANTIBIOTICS
- ✗ NO MICROPLASTICS

The result is a buttery, rich salmon fillet with 18g of protein and Omega-3s, delivering everything people love about salmon, without extracting from oceans or confining animals.

Salmon was just the start. Oshi is expanding its portfolio with whitefish and an exciting surf & turf co-partnership with OffBeast.



SALMON

The world's first plant-based salmon fillet. Flakes like real salmon with rich, authentic taste. Perfect as a center-of-plate protein.



WHITE FISH

Mild, flaky white fish profile. Perfect for tacos, fish & chips, and everyday meals. Clean, light taste.



SURF & TURF

A first-of-its-kind plant-based surf & turf bundle. Two formats, one premium experience.

A DEFENSIBLE MANUFACTURING MOAT IN A \$1.2B MARKET WITH NO SCALABLE ALTERNATIVE

SCALABLE ALTERNATIVE

At the core of Oshi is our patented Modular Layering technology.

Unlike most plant-based seafood products that rely on extrusion or blending ingredients into processed formats, our technology builds fish fillets layer by layer, replicating the delicate fibers that give salmon its signature flake, texture, and cooking performance.

MODULAR LAYERING

For the ultimate process for whole cut fish at scale

- Patented machinery invented by Oshi
- Makes the fish structure and flakey texture of fish
- Easy to integrate in existing lines

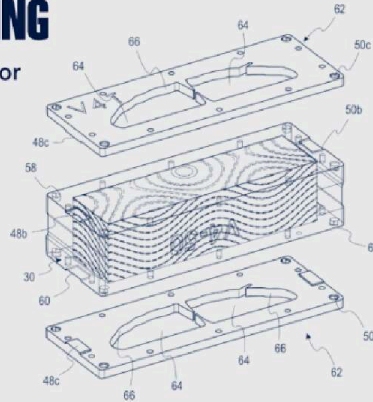

But the breakthrough isn't just culinary, it's manufacturing.

Oshi's production process is designed for scale using standard food manufacturing equipment, enabling a plug-and-play model that can expand through existing facilities rather than building new factories.

The same platform can be used to produce various whole-cut fish formats, from salmon to whitefish and other premium species.

Oshi isn't a single SKU. It's a **SCALABLE SEAFOOD PLATFORM DESIGNED to POWER an ENTIRELY NEW CATEGORY of PLANT-BASED FISH.**



To support global expansion, we have partnered with a large corporation in Brazil to serve the LATAM market.

**NAMED BEST PRODUCT OF 2025
AND LOVED BY 93% OF CUSTOMERS
WHO TRIED IT**

In 2025, Oshi was named Best Product of the Year by Vegpreneur, recognizing the innovation and ambition behind what we have built. The award signals what early adopters already know: this is a breakthrough moment for seafood.

VEGPRENEUR



93% POSITIVE CUSTOMER FEEDBACK

in DIRECT-TO-CONSUMER TRIALS and a TOP SELLER in NEARLY EVERY RESTAURANT that LAUNCHED it

The reviews are consistent: disbelief at the flake, excitement over the texture, and genuine surprise at how close our product comes to the salmon experience they know and love.

Restaurant data shows that bringing Oshi to the menu resulted in a higher ticket value per table that ordered Oshi. This was driven by larger parties like families with a vegan member.







<p>"I honestly couldn't believe it wasn't real salmon. The texture and flavor are unreal. Oshi nailed it!!"</p> <p>— CRAIG, CALIFORNIA</p>	<p>"Finally, a plant-based seafood that actually delivers. Juicy, flaky, and absolutely delicious."</p> <p>— JENNY, NEW JERSEY</p>
<p>"Restaurant-quality at home! I made cooked salmon sushi rolls with Oshi and my whole family was obsessed."</p> <p>— BEN, CALIFORNIA</p>	<p>"Omg the salmon is unbelievable. Wowowow. It was just unbelievable. Borderline creepy."</p> <p>— LISA, COLORADO</p>

Chefs have embraced Oshi with real enthusiasm. They are plating it as a premium entrée, featuring it on menus, and serving it with confidence. In kitchens where texture, structure, flavor, and performance are non-negotiable, Oshi holds its own.

SUPPORTED BY FOODTECH LEADERS WHO HAVE SCALED BILLION DOLLAR BRANDS

Oshi is led by a 4x serial entrepreneur and a team of founders, scientists, and board members who have scaled some of the most disruptive brands in food.

<p>DEEK RON</p>	<p>DR. SAM BERNHARDT</p>	<p>MORAN LAHAT</p>
-----------------	--------------------------	--------------------

<p>Co-Founder & CEO</p> <p>Serial entrepreneur and 2x founder of successful ventures with a track record of helping build one of the world's most prominent vegan communities through Vegan Friendly.</p>	<p>CTO</p> <p>Ph.D. Biochemistry, MBA. New Product development Manager at Pillsbury Israel. Former head of Beverage Technology at SodaStream.</p>	<p>Operations Director</p> <p>Former QA & Food Safety Manager at Aroma Espresso Bar, overseeing quality and safety across multiple locations. Former Project Manager at Sher Consulting & Training.</p>
  	 <p>BJÖRN ÖSTE Advisory Board Member</p> <p>Co-founder of Oatly, a global leader in dairy alternatives. Serial entrepreneur with decades of experience in food innovation and international brand growth.</p> 	 <p>EYAL BRILLER Founding Board Member</p> <p>Former Director of Product at Impossible Foods. MBA from Stanford University. B.Sc. Food Engineering from the Technion.</p> 

Our advisory board includes Björn Öste, co-founder of Oatly, which scaled from a Swedish startup to a \$10B IPO. Our founding board member Eyal Briller led product at Impossible Foods and scaled Hero Bread from 23 to 2,300 stores in under three months.

Before building Oshi, CEO Ofek Ron spent years on the front lines of the food movement – building one of the world's largest vegan communities through Vegan Friendly.

As a founding board member of Vegan Friendly, he mobilized millions. Now he's leading the team that's making plant-based fish a reality.

**IN THE PAST 12 MONTHS,
OUR TEAM...**

 <p>Reduced fillet cost from approximately \$40 to \$6 with a path to \$2</p>	 <p>Increased production capacity from 300 to 1,000+ fillets per shift with a path to 6,000</p>	 <p>Advanced national retail distribution plans targeting 686 doors in 2026</p>
--	--	--

We are experienced food operators who have built billion-dollar brands and scaled into thousands of retail doors. Now, we're channeling our expertise and passion to build the premium plant-based seafood category at scale.

**PLANT-BASED SEAFOOD IS THE
MOST UNDERPENETRATED SEGMENT
IN A \$1B CATEGORY**

In the past two years, the category has experienced a market correction, largely driven by early products focused on highly processed formats like burgers, nuggets, and ground meat. As consumer expectations evolve, the market is shifting toward higher-quality products.



\$1.2B SALES

in 2024

Up from about \$682M
in 2017 – roughly 8%
compound annual
growth.

\$1.2B sales in US seafood market in 2024. US seafood market sales are up from \$682M in 2017.

As the category matures, innovation is moving toward center-of-plate proteins that more closely match traditional meat and fish. This next wave focuses on whole-cut products - steaks, chicken breasts, and fish fillets designed to replicate the structure, texture, and taste of conventional proteins.

61% OF U.S. CONSUMERS
have tried
PLANT-BASED MEAT.

NEARLY 50% OF AMERICANS
say they are actively
trying to **REDUCE THEIR MEAT CONSUMPTION.**



Sustainability is also becoming a major driver of food choices.



ROUGHLY 65% OF GLOBAL CONSUMERS
say **SUSTAINABILITY**
INFLUENCES their **FOOD PURCHASES.**

Despite growing consumer interest in sustainable fish, very few companies have successfully recreated a realistic whole-cut fish product, leaving the space wide open and giving Oshi a timely competitive advantage.

A SCALABLE FOOD PLATFORM BUILT FOR RESTAURANTS, RETAIL, AND GLOBAL DISTRIBUTION

Oshi operates as a classic consumer packaged goods (CPG) model, operating in a blue ocean. Producing whole-cut plant-based fish and selling it wholesale through distributors to grocery retailers and restaurant operators.

Our revenue grows as we expand distribution across restaurants, grocery retail, and

direct-to-consumer channels. Our existing partnerships with restaurants and retailers create a pathway for introducing new products in the same channels.

Together, expanding distribution and launching new products allow us to grow from a single offering into a premium multi-product plant-based seafood brand.

4X REVENUE GROWTH IN 2025 AND ON TRACK TO GLOBAL EXPANSION

Oshi has already demonstrated strong early momentum, with revenue growing 4x year-over-year from \$56K in 2024 to \$222K in 2025. This is just during the pilot phase, setting the stage for a strong transition from pilot production to commercial rollout.

At the same time, we have dramatically improved our manufacturing economics.

Early pilot production cost nearly \$40 per fillet, which we have reduced to roughly \$6 today through equipment improvements and manufacturing efficiencies. With the addition of new high-scale machinery in the US, we expect further cost reductions as production scales, targeting ~\$2 per fillet.

PRODUCTION COSTS DOWN 85%

COST per FILLET

EARLY PRODUCTION	~\$40
TODAY	~\$6
FUTURE TARGET	~\$2



RETAIL PRICE: **\$10.99**

→ STRONG MARGIN POTENTIAL AS PRODUCTION SCALES

As we scale production with larger manufacturing capacity, our costs continue to decline toward price parity with conventional salmon.

Oshi is priced alongside premium salmon, with a retail price of approximately \$10.99 per fillet, positioning Oshi as a center-of-plate fish protein rather than a processed meat alternative.

Whitefish is next on the horizon, with additional premium species planned as we expand into new seafood categories and grow revenue across multiple SKUs.

OSHI IS RAISING ITS SERIES A TO FUEL THE EXPANSION



→ Product MVP
→ Machine POC

→ US Co-manufacturer
→ US foodservice launch

→ US Retail launch
→ IL Launch
→ Entering LATAM market
→ WhiteFish Launch

→ Started the company

→ Pilot production
→ Product V1.0

→ D2C Launch
→ US Foodservice expansion

→ Blue Algae Fish launch
→ International foodservice & retail growth

We have the privilege of not having to adhere to a specific species and getting flak for not being the same. We can create seafood offerings that are just delicious and innovative. We can focus on using specific ingredients as our main flavor profile instead of mimicking a species.

LARGE FOOD COMPANIES DON'T BUILD DISRUPTIVE CATEGORIES, THEY BUY THEM

Over the past decade, category-defining plant-based companies have reached multi-billion dollar valuations as consumer demand shifts toward sustainable protein and global food companies race to be the category leaders.

Rather than building new products internally, many of the world's largest food companies have chosen to acquire fast-growing plant-based brands that demonstrate strong consumer demand and category leadership.



WHOLE CUT SEA FOOD BLUE OCEAN



As the category develops, companies that successfully define the whole-cut seafood segment are likely to become strategic targets for major food companies seeking leadership in sustainable protein.

With patented technology, scalable production, and early commercial traction, Oshi is positioned to become one of those category leaders.

Future projections are not guaranteed.





Oshi is trailblazing the whole-cut plant-based fish category, bringing a true salmon fillet experience to one of the most consumed fish in the world, without fishing the oceans or harming animals.

Over the past 12 months, Oshi has 4x'd revenue, expanded to 100+ restaurant menus, and is now preparing for a retail launch targeting 686 stores. This is just a preview of what's in store ahead.

Now, we're opening the door for our passionate community of food lovers, ocean advocates, and conscious consumers to invest alongside leading venture capital firms who have backed some of the most successful plant-based brands of our time like Oatly and Impossible Foods – as we launch our next phase of growth with a new strategic manufacturing partnership.

Together, we can build the next category leader in plant-based seafood.

wefunder.com/oshi