

OFFERING MEMORANDUM

PART II OF OFFERING STATEMENT (EXHIBIT A TO FORM C)
**Revised to accommodate a Change of Intermediaries
(a continuation Amendment of the OFFERING)**

Locking Line Barriers Corporation

dba

WATERBLOCKS

4155 E. Jewell Ave.

Suite 610

Denver, CO 80222

www.WaterBlocks.NET



5000 shares of Class B Non-Voting Common Shares

A crowdfunding investment involves risk. You should not invest any funds in this offering unless you can afford to lose your entire investment.

In making an investment decision, investors must rely on their own examination of the issuer and the terms of the offering, including the merits and risks involved. These securities have not been recommended or approved by any federal or state securities commission or regulatory authority. Furthermore, these authorities have not passed upon the accuracy or adequacy of this document.

The U.S. Securities and Exchange Commission does not pass upon the merits of any securities offered or the terms of the offering, nor does it pass upon the accuracy or completeness of any offering document or literature.

These securities are offered under an exemption from registration; however, the U.S. Securities and Exchange Commission has not made an independent determination that these securities are exempt from registration.

THE OFFERING

Revised and amended only to accommodate the Change of Intermediaries

***** SPECIAL NOTICE *****

The acceptance of Stock Tender Offers for this Offering Terminated April 30, 2018, the FORMER Intermediary reported as of this date the Issuer had accepted and closed Stock Tender Offers from 1,258 Investors and Received \$574,432.00 in Gross Proceeds, thereby having issued 287,216 shares of its Class B non-voting Common Stock Shares of the 535,000 shares Offered. Leaving a remainder of 247,784 Shares available in this Offering, to be transacted by the new Intermediary, TruCrowd.

The Issuer intends to leave this Offering available to the public on the TruCrowd Portal website until the remaining 247,784 Shares have been transacted in accordance with SEC rules and regulations. However, the Issuer reserves the right to terminate this offering at any time as may be determined by the Issuer.

Offering Details

Maximum 535,000 shares of Class B Non-Voting common stock (\$1,070,000)

Minimum 5,000 shares of Class B Non-Voting common stock (\$10,000)

Company: **Locking Line Barriers Corporation dba WATERBLOCKS**

Corporate Address: 4155 E. Jewell Ave. Suite 610 Denver, CO 80222

Description of Business: Exclusive Global Licensee and Distributor of the WaterBlocks Products and Services.

Helping Save Lives, Communities and our Environment.

Type of Security Offered:	Class B Non-Voting Common Shares
Purchase Price of Security Offered:	\$2.00
Minimum Investment Amount	100 Shares
(per investor / per transaction):	\$200.00

Multiple Closings

If we reach the target offering amount prior to the offering deadline, we may conduct the first of multiple closings of the offering early, if we provide notice about the new offering deadline at least five business days prior (absent a material change that would require an extension of the offering and reconfirmation of the investment commitment).

THE COMPANY AND ITS BUSINESS

Description of Business

Locking Line Barriers Corporation (LLB) dba WaterBlocks is a Colorado Corporation formed October 10, 2015 for the purpose of accepting a twenty (20) year exclusive license (the License) and related rights to globally exploit, market, sub-license and distribute the product(s) now known as the trademarked name "WaterBlocks", their accouterments and related services as developed. The License was issued to LLB by Great American Holdings, Inc. a Colorado Corporation, created in March 2009, for the purpose of holding and providing a safe harbor for the ownership and related rights to the intellectual property created by its shareholders.

Our steel reinforced polyethylene products Link and Lock together utilizing magnetic vinyl seals to create a plastic wall of protection while preventing liquid penetration at the joints to provide a dry side of protection and re-direction of drainage fluids and flood waters.

The initial “Flood Control Design” has been modified numerous times during the past three years to accommodate improvements and new innovations to expand the versatility and usage applications of the products and thereby expand the potential market for the product. The most notable design changes include:

Specialized 2-way doors: To permit barrier filling water to be added both by mechanical means and by the rising flood waters automatically. This design permits the barrier to be emptied quickly and provide access to utilize mechanical lifting of the barriers.

The inclusion: Of an opening in the center of the male joint to accept the insertion of a standard steel fence pole in the joint. The water filled barriers provide a suitable foundation to permit the addition of multiple types of fencing (walls) of suitable height, added as needed.

Double Stacking Capability: Design changes permit (1) cube of (2) barriers to lock a third barrier on top of the cube and thereby increase the height of the stack to 8 Feet, final dimensions for such a stack would be 4' L x 4' W x 8' H. When water filled: the stack would increase the stack weight from approximately 150 lbs. empty to 5,250 lbs.

Permanent Markings: Permanently molded into the plastic for the life of the product with custom colors on the barriers on the Billboard Style front area which allows for custom artwork, logos and notifications to be emblazoned permanently into the product.

New Polyethylene Resins: Guaranteed to extend product life to a minimum of 18 to 20 years.

Block Wall Unitization: We have designed, developed and filed for patent protection as to the means and methodology to unitize and lock together a double stacked wall of Locking Line Barriers in such a fashion as to be able to stop a rubber tired vehicle, such as a semi-trailer truck with a 40,000 lb. load of cargo, traveling at 50mph dead in its tracks. We estimate no more than about 20' of wall movement resulting from such an impact as the wall collapses around the vehicle, minimizing any exploding shrapnel as it is absorbed by the water in the barriers.

The Block Wall Logic: To block a standard 29' wide street, unitizing a 28' long wall of double stacked barriers 8' tall and 4' of width, unitized as a single blockade. Creating a wall of water providing an impact force barricade of approximately 36,000 lbs. of dead weight stopping power. Each of the 21 separate blocks have an impact resistance of approximately 5,000 lbs. or 100,000 lbs. combined. We believe the impact force required to penetrate the wall of water would result in the complete destruction of any known rubber tired vehicle in existence today.

LLB intends to seek Grant(s) of \$1-\$2M from either or both Home Land Security and the Department of Defense to fund an actual physical test of this feature.

Today our product line has evolved from just a flood control system to a multi-use product line with the versatility and unique features capable of providing solutions in multiple markets.

Tomorrow we will build a Barrier Sharing Network (BSN), a web based cost sharing system for

organizations to go online and RENT the barriers by ordering the Barriers needed in real time, for delivery on our mobile warehouses (53' TruckTrailers). This system makes the barriers AFFORDABLE to every organization.

Sales and Supply Chain

LLB initial sales efforts are focused on six key target markets:

1. Product Sales to government agencies and municipalities
2. Product Sales to major corporations in the Construction and Petroleum industries, Government agencies, municipalities and major corporations - informing and educating the largest group of ultimate users about the product and determining their potential needs and enrolling them as members in BSN. This segment includes building a BSN Labeled truck trailer with a full load of barriers, to take to trade shows and other related events around the country.

Eventually, we intend to obtain a GSA Contract, permitting Procurement Officers throughout the Federal Government, including FEMA to readily purchase the product line on a pre-established price list without a bidding process requirement.

3. Distributorship Development and Expansion domestically and globally

We have received one licensing inquiry from Mexico, some interest from Holland and anticipate formulating a worldwide licensing program upon completion of the utility patent process.

4. Sponsorship sales to major Corporate Social Responsibility (CSR) departments for BSN inventory Directed at CSR (Corporate Social Responsibility) departments of the Fortune 2000 companies. This product provides for a high impact long-term return on the message/advertisement chosen, be that either the corporate identity i.e., "Verizon" and/or a specific product i.e., "This Bud's For You!"

5. Crowdfunding Revenue Sharing Agreement Investments in BSN inventory expansion

6. Revenue Sharing Agreement Investment Sales and Grants from Charitable 501c3 organizations for BSN inventory expansion based on the following:

Foundations – 501c3 organizations – sponsorship grants to provide our product to those in need while providing the organization with recognition of their contributions to help protect lives and property.

We recently entered into an agreement with a related, newly formed 501c3 charitable organization, the Disaster Support Foundation (DSF), for grants and donations to acquire and provide our Barriers for the Barrier Sharing Network. This arrangement provides Sponsors with the opportunity to utilize the charitable tax advantages versus advertising expense deductions when participating in the Barrier Sharing Network.

There is over \$1 Trillion held by over 80,000 "501-c3's" looking for Social Impact investments in the US. DSF intends to offer these organizations investment opportunities through a 'Revenue Sharing Agreement' to participate in BSN.

Competition

The Fluvial barriers have been sold in Europe for a number of years and recently introduced to the US. The issues that this product has include the handling and shipping configurations which are cumbersome and not cost effective. The product comes with two holes on the wet-side of the barrier to allow water to enter and exit unfettered. Consequently, to provide the necessary ballast to hold them in place requires a 65lb. key used to join two units together made of plastic filled with concrete. This is another shipping and handling issue as well. However, it's similarity and success does prove the viability and marketability of such a product as ours.

Both product lines (WaterBlocks and Fluvials) are made of similar polyethylene material and manufacturing process.

Liabilities and Litigation

None

We are ready to GO TO MARKET!

The Team

Officers and directors

Name	Position(s)	Dates of Service
Joe Daniluk	CEO & Director	10/10/2015 - Present
Steve Tannenbaum	Director Finance	10/12/2015 - Present
Ambassador Sam Zakhem	Director Government Relations	10/12/2015 - Present
Will Hunziker	Director Patent & Licensing	10/12/2015 - Present
Scott Saxman	Product Development & Global Expansion Director	10/12/2015 - Present

Joe Daniluk

A Denver native, Joseph is a service disabled combat veteran, married with two children. Joe's favorite pastimes include skiing, flying and financial market analysis. He brings more than 30 years of business development experience for directing and managing new project development with an emphasis in finance, automation and marketing. He is also a licensed Colorado Real Estate Broker and Private Pilot. A graduate of the University of Denver with a dual degree in Finance and Real Estate and a minor in Mass Communications and TV Production. He has an extensive computer background with training in the US Navy Tactical Data Systems military computer systems and later migrating to PC's, designing and building computers, LAN's, Enterprise systems and WEB hosting networks. During the savings and loan crisis, he was the Assistant Specialist in Charge (ASIC) of the Denver FDIC office managing 330 employees and managing and liquidating \$2.5 billion of assets recovered from closed banks and S&L's. From 1999-2014 Joseph managed SuperLoads, Inc. as CEO, a specialized freight company, moving the big, the bad and the ugly freight (150,000 to 1,000,000 lbs.) throughout North America. He obtained the only authority issued by Lloyd's of London to insure spot rail freight, which gave him a \$5 million underwriting authority. Clients included moves for NASA, SpaceX, GM, Ford Berkshire Hathaway, CH Robinson, CAT, Hyundai Heavy Industries, Fairbanks Power and Light, Pennsylvania Power and Light, Siemens and many others. Since 2006, he has been CEO of,

Manufacturing Contractors, Inc., a plastic manufacturing operation providing Nuclear Waste liners for the Department of Energy and other plastic products to the USDA. LLB's product line is manufactured in the same manner and process as Manufacturing Contractors' Nuclear Waste Liners. Mr. Daniluk, is presently and for at least the past three years, the owner and operator (Director and CEO) of the following businesses: CEO and Director of Locking Line Barriers. Approximately spends 30 hours weekly and is his Primary job. 2015 to present. CEO and Director of Great American Holdings, Inc. (Asset Holding and Management) 2015 to present. CEO and Director of Strategic Solutions Team, Inc. (General Business Consulting) 2015 to present. CEO and Director of Manufacturing Contractors, Inc. (Plastic and Steel manufacturer) 2015 to present. Executive Director of Disaster Support Foundation (Charitable Organization) 2015 to present.

Steve Tannenbaum

President of Tannenbaum Consulting LLC, Steve has a diverse background with over 30 years of experience in tax, auditing and accounting services. He has testified as an expert witness in Federal, District and County Courts as well as evaluated commercial enterprises and actively participated in negotiations relative to business acquisition and reorganization, restructuring, and dissolution. Steve brings to the table extensive history and experience working with businesses engaged in manufacturing, wholesale and retail sales, construction, mortgage banking, professional practices, and commercial and residential real estate. Steve received a B.S. in Accounting from the University of Colorado in 1975 and a B.A. in Psychology from the University of Colorado in 1973. He is a Certified Public Accountant in the State of Colorado and a member of both the American Institute of Certified Public Accountants and the Colorado Society of Certified Public Accountants. Mr. Tannenbaum is the former President of Tannenbaum & Suber, P.C. and former tax partner at Deloitte & Touche. From: 2015 To: Present Is an Officer and Director of Tannenbaum & Company, P.C. (CPA Consulting and Tax Services)

Ambassador Sam Zakhem

Sam was appointed US Ambassador to Bahrain by President Ronald Reagan to serve the Middle East in 1986 and served with distinction during very volatile times. Sam also served his country as a White House Advisor, a member of the US Small Business Administration, and Chaplain in the US Navy. Sam has also been involved in the legislature of his home State, Colorado as a State Senator, and two term State Representative. In business, Sam has held various positions including CEO and Vice President of companies including Ford Motor Co., Denver University, The Heritage Foundation and others. Fluent in multiple languages, Sam has numerous degrees from various Universities both here and abroad, has served on their advisory boards as well as taught from time to time. Senator Jesse Helms heralded Ambassador Zakhem as follows: "You have the courage of your convictions and the moral and spiritual principles to guide you in rendering distinguished service to our country. You stood up to America's enemies in your courageous service as U.S. Ambassador to Bahrain. Not once have you compromised your willingness to fight to preserve the freedoms of the American people." From: 2015 to: Present he is a Business Advisor & Public Speaker as a Self Employed (Consultant)

Will Hunziker

Will is a registered practicing patent attorney in Denver and Boulder, specializing in patent, trade secret, trademark, copyright searching, licensing, registration, prosecution, and litigation. As LLB's primary patent counsel, he will manage outside law firms retained to pursue the protection

of the company's intellectual property and licenses. Graduating from University of Colorado with a Bachelor's Degree in Molecular, Cellular & Developmental Biology that included studies in genetic engineering, chemistry, biology, physics, and mathematics, Will also received a Bachelor's Degrees in both English and Philosophy: Law and Society. Will earned his Juris Doctor from Seattle University School of Law. Will is active in several organizations as a member of the Federal District of Colorado, and Boulder Bar Associations, Better Business Bureau, Boulder Chamber of Commerce, Boulder / Front Range Mensa, and various business and technology Meetup Groups. From: 2015 To: Present Is an Officer and Director of Hunziker Legal Services, PLLC (Attorney at Law).

Scott Saxman

Scott is currently the Corporate Business Development Director and former Senior Vice President of Sales & Marketing at Mold In Graphic Systems, where he's spent 25 years providing products and services to the worldwide rotational molding industry. Previously, he served for six years as Director of Marketing & Sales at Flexible Flyer Toys focused on the ongoing development of new lines of plastic toys. Prior to that he served as Marketing & Product Development Manager at Hedstrom Plastics Corporation, a leading rotational molding plastic manufacturer. Educated at Indiana University with a Bachelor's in Business and Economics, his extensive international and domestic business and product development skills as well as his 37+ years of broad experience in the field of rotational plastic molding and manufacturing have been invaluable to LLB. From: 2015 To: Present Is a Business Development Director of Mold In Graphic Systems (Graphic Provider for Plastics)

Number of Employees: 1

Related party transactions

Since the Company's inception and through December 29, 2017, the Company has been held in operational abeyance pending this offering. By its incorporators, financial supporters and related parties, including; Great American Holdings Inc., Manufacturing Contractors Inc., Strategic Solutions Team Inc., all of which are controlled by Joseph Daniluk, CEO of the Company, Locking Line Barriers Corporation, its controlling stockholder, along with approximately, two dozen other parties, now related parties, in order to develop and prepare the Company to become transactional and begin conducting business. Transactions by and between the Company and the related parties will be ongoing for the foreseeable future in support of the company and its ongoing business. The estimated cash value of the investment(s) realized to date "founders contributions" including, but not limited to; deferred compensation, credit facilities provided, services rendered, and other effective contributions for the entire "WaterBlocks Project" is estimated at \$4 million, with an undefined portion thereof for the benefit of the Company. These "founders' contributions" benefiting the Company have been fully compensated for through the issuance of the Company capital stock. Thereby resulting in a debt-free Corporation, consisting of two Assets: a.) The Global Distribution License and b.) \$100 cash to open the business checking account, with No Liabilities. Further, the intellectual property, related patents (see Risk Factors), of the WaterBlocks product line, is held by Great American Holdings, Inc., and divided into two categories; manufacturing and marketing, distribution. The exclusive 20 year

manufacturing license has been granted to Manufacturing Contractors, Inc. and the exclusive 20 year marketing and distribution license has been granted to the Company, Locking Line Barriers Corporation, both of which are related parties.

RISK FACTORS

These are the principal risks that related to the company and its business:

- **Risk Disclosures** The SEC requires the Company to identify risks that are specific to its business and its financial condition. The Company is still subject to all the same risks that all companies in its business, and all companies in the economy, are exposed to. These include risks relating to economic downturns, political and economic events and technological developments. Additionally, early-stage companies are inherently more risky than more developed companies. You should consider general risks as well as specific risks when deciding whether to invest. These are the principal risks that relate to the Company and its business: **Competitive Risks** Once the product is in use, we anticipate many
- ‘copycats’ may try to redesign the basic concepts and attempt to compete with this product. Patent infringement and development costs may deter such attempts. LLB believes, once the Barrier Sharing Network is operational, this network service will negatively impact the ‘copycat profitability equation’, as an investment in a costly competitive product that is readily available through the Network at minimal cost may thwart copycats.
- **Marketing and Sales Risks** There has been no similar product or related advertising scheme on the market in the US prior to 2016. Consequently, there is no data upon which to formulate metrics for company valuations, marketing, sales and profitability, analysis or other common types of investment due diligence. All projections and forward-looking statements contained herein are simply estimates the company believes to be reasonable. Standalone sales of the product, without advertising, will take place primarily with government agencies, where ownership and control of the product is more important than the cost factor. This may also be true for some large corporations. We anticipate less than 40% of our revenue will come from this source of sales during the first three years of operations, due to the lag time normally encountered with such organizations to execute such a purchase. Our target market is other municipalities, agencies and other business enterprises which have an interest in a cost sharing methodology for the acquisition of disaster support equipment.

We will be relying on need versus cost for the successful marketing of our Products and Network memberships. Membership fees and nominal equipment rental charges are anticipated to provide only an estimated 10-15% of our revenue during our first three years of operations. All sales of the WaterBlocks product line must, contractually, come through LLB. We anticipate the bulk of our sales and revenues to be generated from our marketing efforts and the marketing efforts of our affiliates and future distributors. This would include the sale of “Barrier Sharing Network Revenue Sharing Agreements” by and through LLB and its affiliates. There having been no such sales or efforts to sell revenue sharing agreements to date, LLB is unable to provide any reliable forecast or expectation regarding the viability of such sales. Advertising Sales to sponsors and donors is estimated to generate 10-15% of the company’s revenue. It is possible the company could completely fail in this marketing endeavor. The company has no previous experience in selling or marketing advertising. There are no competitive similarities to this advertising medium, or any other known facts to formulate standard advertising industry sales metrics as to impressions or cost per

impression. Such advertising sales will remain conceptual, for the most part, until such time as the barriers are shown working and controlling floodwaters on national news. The only factor making such sales conceivable is the low advertising cost/rate when amortized over the life of the product and the advertisement thereon.

- Ordinary, normal and common startup company Risks This company is a Start- Up. It is a high risk venture, an unknown undertaking, that will be subject to all the risks experienced by any new startup company. There are no known management personnel available with previous experience in this specific endeavor. There are no known competitors to provide related comparisons. The one and only known factor available to the Company is the "Demand for such a product and rental service", which is enormous. The challenge is the Company's ability to bring the product and service to market successfully.
- The company depends on one primary product line and related services to start. Others will be developed and added as the opportunities to do so permit. The company's primary product is the WaterBlocks Product Line. Although it is developing other products, the company's survival in the near term depends upon being able to sell or rent the WaterBlocks in sufficient quantities to make a profit.
- The delivery of the Company's product line is dependent upon third-party manufacturers. The company's primary product is manufactured by third parties. The Company, by Contract is required to purchase the product from the licensed exclusive Manufacturer and must rely on the manufacturer for the products and related warranties. Difficulties encountered by the manufacturer may result in the inability to deliver product or in a timely manner, the Company may be impacted.
- If the company is unable to raise sufficient funding. It will not succeed. There can be no assurance that the company will meet our projections, goals and/or objectives. There can be no assurance that there will be sufficient acceptance of product to succeed.
- The company is controlled by its CEO LLB's CEO also controls the owner of the intellectual property rights, Great American Holdings, Inc., and Manufacturing Contractors, Inc., the exclusive manufacturer of the WaterBlocks product line. Patent /
- Intellectual Property License Risks: Locking Line Barriers Corporation, LLB's, only intellectual property rights are those rights conveyed in the Global Distribution and Licensing Agreement. LLB has no other rights to or in the intellectual property related to the "WaterBlocks" project. LLB has a legal obligation under its license agreement to pay all related costs and expenses to develop, expand and protect the existing intellectual property rights in consideration of having the control of the expansion of the intellectual property rights and the exploitation thereof globally. The related Product License(s) we rely on for various underlying intellectual property rights in order to minimize competitive impact on the operation our business including pending patents, may not be sufficiently broad or otherwise may not result in a significant competitive advantage. In addition, the steps that we are required to take to maintain and protect the intellectual property rights may not prevent our rights from being challenged, invalidated, circumvented or designed-around, particularly in countries where intellectual property rights are not highly developed or protected. In some circumstances, enforcement may not be available to us because an infringer has a dominant intellectual property position or for other business reasons. Any failure by the Company to obtain or maintain intellectual property rights that convey competitive advantage, adequately protect the intellectual property or detect or prevent circumvention or unauthorized use of such property, could adversely impact our

competitive position and results of operations. We also rely on nondisclosure and noncompetition agreements with vendors, consultants and other parties to protect, in part, trade secrets and other proprietary rights. There can be no assurance that these agreements will adequately protect our trade secrets and other proprietary rights and will not be breached, that we will have adequate remedies for any breach, that others will not independently develop substantially equivalent proprietary information or that third parties will not otherwise gain access to our trade secrets or other proprietary rights. As we expand our business, protecting the intellectual property rights will become increasingly important. The protective steps we have taken may be inadequate to deter competitors from using the proprietary information. In order to protect or enforce our intellectual property rights, we may be required to initiate litigation against third parties, such as infringement lawsuit(s). Further, these third parties may assert claims against us with or without provocation. Such lawsuits could be expensive, take significant time and could divert management's attention from other business concerns. The law relating to the scope and validity of claims in the technology field in which we operate is still evolving and, consequently, intellectual property positions in our industry are generally uncertain. We cannot assure you that we will prevail in any of these potential suits or that the damages or other remedies awarded, if any, would be commercially valuable. Patent, processes, maintenance and infringement enforcement costs could be significant as the product is expanded to other countries. Many of the patent pending accouterments claimed could be rejected by the examiners, which won't be known for some time.

- **General Start Up Business Risks** Locking Line Barriers Corporation, LLB, is a StartUp, it has no transactional history. It only possess a License to develop and market a new idea, which has no comparable to rely upon for data or guidance on how to proceed. Certain other RISKS may exist and remain unknown or unforeseen and thereby not specified in this offering. Therefore, there are no guarantees of any kind that the business can succeed and prosper. The Company and its Team can only put forth its Best Efforts to proceed in accordance with this offering and representations.

OWNERSHIP AND CAPITAL STRUCTURE; RIGHTS OF THE SECURITIES

Ownership

The name and ownership level of each person, as of the most recent practicable date, who is the beneficial owner of 20 percent or more of the issuer's outstanding voting equity securities, calculated on the basis of voting power.

<i>Name of Holder</i>	<i>No. and Class of Securities Now Held</i>	<i>%Voting Power Prior to Offering</i>
<i>Joseph Daniluk</i>	1,200,000 Class A Common Shares	13.33%
<i>Great American Holdings</i>	4,400,000 Class A Common Shares	48.89%

Classes of securities

- Class B Non-Voting Common Stock: 1,500,000
Voting Rights (*of this security*) **NONE**

The holders of shares of the Company's Class B Non-Voting Common Stock, no par value per share are not entitled to vote individually and/or cumulatively on any matters submitted to a vote of the shareholders except as required under applicable law.

Dividend Rights (*include if applicable*)

Subject to preferences that may be granted to any then outstanding preferred stock, holders of shares of Common Stock, by Class, are entitled to receive ratably such dividends as may be declared by the Board out of funds legally available therefore as well as any distribution to the shareholders. The payment of dividends on the Common Stock will be a business decision to be made by the Board from time based upon the results of our operations and our financial condition and any other factors that our board of directors considers relevant.

Payment of dividends on the Common Stock may be restricted by law and by loan agreements, indentures and other transactions entered into by us from time to time. The Company has never paid a dividend and does not intend to pay dividends in the foreseeable future, which means that shareholders may not receive any return on their investment from dividends.

Rights to Receive Liquidation Distributions

Liquidation Rights. In the event of our liquidation, dissolution, or winding up, holders of Common Stock are entitled to share ratably in all of our assets remaining after payment of liabilities and the liquidation preference of any then outstanding preferred stock or other legal obligations. Rights and Preferences. The rights, preferences and privileges of the holders of the company's Class B Common Shares are subject to and may be adversely affected by, the rights of the holders of shares of any series of our Class A Common Shares, Preferred Shares and any additional classes of preferred stock that we may designate in the future.

- Class A Voting Common Stock: 7,500,000

Voting Rights (*of this security*)

The holders of shares of the Company's Class A Voting Common Stock, no par value per share ("Voting Common Stock") are entitled to one vote for each share held of record on all matters submitted to a vote of the shareholders. The holders of Non-voting Common Stock are not entitled to vote on any matter except as required under applicable law.

Dividend Rights (*include if applicable*)

Subject to preferences that may be granted to any then outstanding preferred stock, holders of shares of Common Stock are entitled to receive ratably such dividends as may be declared by the Board out of funds legally available therefore as well as any distribution to the shareholders. The payment of dividends on the Common Stock will be a business decision to be made by the Board from time based upon the results of our operations and our financial condition and any other factors that our board of directors considers relevant. Payment of dividends on the Common Stock may be restricted by law and by loan agreements, indentures and other transactions entered into by us from time to time. The Company has never paid a dividend and does not intend to pay dividends in the foreseeable

future, which means that shareholders may not receive any return on their investment from dividends.

Rights to Receive Liquidation Distributions

Liquidation Rights. In the event of our liquidation, dissolution, or winding up, holders of Common Stock are entitled to share ratably in all of our assets remaining after payment of liabilities and the liquidation preference of any then outstanding preferred stock or other legal obligations.

Rights and Preferences

The rights, preferences and privileges of the holders of the company's Class A Common Shares are subject to and may be adversely affected by, the rights of the holders of shares of any series of our Class B Common Shares, Preferred Shares and any additional classes of preferred stock that we may designate in the future.

- Preferred Stock: 0

Authority is vested in the board of directors of the corporation to prescribe, in a resolution providing for the issuance of such shares, the classes, series, the number of each class or series of stock to be issued and the voting powers or no voting powers, designations, preferences, limitations, restrictions and relative rights of each class or series of stock. The corporation shall have one or more classes of shares that together have unlimited voting rights and one or more classes that together are entitled to receive the corporation's net assets upon dissolution. There are currently no rights designated for preferred stock, and there is no plan or intent to issue any Preferred of any type or class at this time.

What it means to be a Minority Holder

The only stock being offered herein by Locking Line Barriers Corporation is its Class B NON-voting common shares held in treasury, please be advised:

In our Company, the classes and voting structure of our stock has the effect of concentrating voting control with a few people, specifically the founders along with a small number of shareholders. As a result, these few people collectively have the ability to make all major decisions regarding the Company.

As a minority holder of Locking Line Barriers Corporation's Class B NON-Voting common shares, you will have limited ability, if any at all, to influence company policies or any other corporate matter(s), including the election of directors, changes to the Company's governance documents, additional issuances of securities, company repurchases of securities, a sale of the Company or of assets of the Company, or transactions with related parties.

Dilution

Investors should understand the potential for dilution. Each Investor's stake in the Company, could be diluted due to the Company issuing additional shares. In other words, when the Company issues more shares, the percentage of the Company that you own will increase, even though the value of the Company may increase. You will own a smaller piece of a larger company. This increase in number of shares outstanding could result from a stock offering (such as an initial public offering, another crowdfunding round, a venture capital round or angel

investment), employees exercising stock options, or by conversion of certain instruments (e.g., convertible notes, preferred shares or warrants) into stock.

If the company decides to issue more shares, an Investor could experience value dilution, with each share being worth less than before. There may also be earnings dilution, with a reduction in the amount earned per share (although this typically occurs only if we offer dividends, and most early stage companies are unlikely to offer dividends, preferring to invest any earnings into the Company).

The type of dilution that hurts early-stage investors mostly occurs when the company sells more shares in a "down round," meaning at a lower valuation than in earlier offerings.

If you are making an investment expecting to own a certain percentage of the Company or expecting each share to hold a certain amount of value, it is important to realize how the value of those shares can decrease by actions taken by the Company. Dilution can make drastic changes to the value of each share, ownership percentage, voting control, and earnings per share.

PLEASE ensure you review other investment risks disclosed in our RISK DISCLOSER Section, herein.

Transferability of securities:

For a year, the securities can only be resold:

- In an IPO; and/or
- To the company; and/or
- To an accredited investor; and/or
- To a member of the family of the purchaser or the equivalent, to a trust controlled by the purchaser, to a trust created for the benefit of a member of the family of the purchaser or the equivalent, or in connection with the death or divorce of the purchaser or other similar circumstance.

FINANCIAL STATEMENTS; FINANCIAL CONDITION MATERIAL INDEBTEDNESS

Financial Statements

Our financial statements can be found attached to this document. The financial review covers the period ending in 2017-12-31. Current Financial Statements are file with the SEC each year see SEC Form C-AR filings and/or at the Issuer's Corporate Website: <https://llbusa.com/public-documents/accounting/>

Financial Condition and Results of Operation:

The company has no operating history and has not yet generated any revenues and does not anticipate doing so until we have completed the funding for the purchase and delivery of product, which we do not anticipate occurring until this offering closes. Until we purchase the product we anticipate no major expenses occurring. Staffing will not occur until the company has sufficient capital to meet the costs.

Based on our forecast, with the liquidity of the anticipated full raise amount, we anticipate that

we can operate the business for 10 months without revenue generation. In the event the Company is successful in completing this funding, the funds will be utilized in accordance with the "Use Of Proceeds" described in this offering.

Further, We have a robust Capital Funding Plan and will likely seek to continue to raise capital in the form of equity, debt and/or revenue sharing agreements, or any other method available to the Company.

The Company being a Start-Up business with no assets, cash flow or transactional history is unable to establish conventional "commercial credit". The Company has developed and will expand what it refers to as "Private Credit Facility (PCF)" defined for accounting and operational purposes as "PCF Debit and Credit Transactions" received from or payable to; vendors, investors, organizations, related parties, and others, who may provide effectively credit and/or funds in kind to the Company, as need from time to time, requiring repayment in relatively short time periods of cash. debt instruments and/or equity.

Further, our liquidity will receive a positive impact by and through potential sales of the WaterBlocks product line and related services, as well as the sale of Distributor Sub-License Agreements.

Financial Milestones

The Company is investing in growth of the brand and inventory for sales and networking rental inventory resulting in net income losses as a result.

Liquidity and Capital Resources

The Company is dependent upon its capital funding efforts and resulting resources to begin and pursue its operations. These capital resources will come from the Company's CF Regulated funding efforts through one or more venues and/or sources. Specifically, the Company intends to take the following capital funding steps:

2018:

- Initial Offering;\$107,000 if successfully completed, continue to;
- Amend the Offering with an increase of \$240,000, if successfully completed, continue to;
- Initiate a following offering to the legal limit of \$1,070,000.

2019:

- Initiate a New CF-Regulated offering up to the legal limit of\$1,070,000.

In Addition:

We have a robust Capital Funding Plan and will likely seek to continue to raise capital in the form of equity, debt and/or revenue sharing agreements, or any other method available to the Company.

The Company being a Start-Up business with no assets, cash flow or transactional history is unable to establish conventional "commercial credit". The Company has developed and will expand what it refers to as "Private Credit Facility (PCF)" defined for accounting and operational purposes as "PCF Debit and Credit Transactions" received from or payable to; vendors, investors, organizations, related parties, and others, who may provide effectively credit and/or funds in kind to the Company, as need from time to time, requiring repayment in relatively short time periods of cash. debt instruments and/or equity.

Further, our liquidity will receive a positive impact by and through potential sales of the WaterBlocks product line and related services, as well as the sale of Distributor Sub-License Agreements.

Indebtedness

The Company has no debt or material terms of indebtedness.

Recent offerings of securities

Date of Offering	Exemption Relied Upon	Securities Offered	Amount Sold	Use of Proceeds
2021-08-12	Rule 506(c)	Preferred Series 1 Stock	\$22,000.00	Includes outside advertising and promotions, offering management fees, legal/accounting fees, compliance fees, and future potential finders' fees to executive officers, directors, existing shareholders, and board advisors.

Valuation

\$18,000,000.00

The Pre-Money Valuation has been formulated as follows: (Total Shares Issued X Offering Price) = Valuation (9,000,000 X \$2.00) = \$18,000,000 and further; We have not undertaken any efforts to produce a valuation of the Company. The Board of Directors determined that a Price of \$2.00 per share was a reasonable sale price of the outstanding Shares held in Treasury for this offering. Valuation Discussion: The price of the shares merely reflects the opinion of the Company as to what could be the fair market value. When incorporating "Blue Sky" value of the Intangible Assets, including, but not limited to; three years of R&D, licenses and related trademark rights, web site and marketing tools and copyrights, and revenue potential. The actual value can only be determined when a willing purchaser pays and the seller accepts the price offered. Financial Statement correlation; the CEO elected to value the Company's Intangible Assets at \$0.00 as no reasonable valuation formulation could be determined. The single most important intangible asset of the company is its 20 year Global Marketing License for the WaterBlocks product line and at the time financial statement were prepared no comparative valuation could be found. The Company believes that this license will result in a minimum average CTOE (cash throw off to equity) of \$2m annually over the first 20 years of the license. Our mathematical analysis, for a Discounted Future Value of the CTOE; using the 20 Year Life of the Global Distribution License,

a forecast of an average \$2M annually in CTOE, discounted at 10%, results in a Present Value of \$23.8M; Source; Motley Fool – xcalc. Conclusion: In considering the value of the Company's unrestricted Global Distribution License we included the only similar comparable we have found. The recent article disclosing Nestle's purchase of the restricted by market segment, Global Distribution Rights from Starbucks. Insufficient data precludes a comparative analysis, but the transaction does shed some light on the value of Global Distribution Rights. Article Source "The Denver Post, May 8, 2018, page 15 by AP" NESTLE TAKES OVER SALES OF STARBUCKS IN

GROCERY AISLES Seattle: Nestle is paying more than \$7 billion to buy the rights to sell Starbucks coffee and tea in supermarkets and other stores outside its coffee shops. The deal comes with a huge price tag for Nestle. but it could pay off big for the- Swiss company. Its Nescafe and Nespresso don't carry anywhere near the heft in America that the Starbucks brand does, with its \$2 billion in annual sales. Nestle will also put Starbucks in grocery stores outside the U.S. and Canada. The deal gives Nestle the rights to market, sell and distribute bags of Starbucks coffee beans, as well as its instant coffee. Nestle will also sell other brands owned by Starbucks, such as Seattle's Best Coffee, Teavana tea and Torrefazione Italia coffee, and will be allowed to put the Starbucks brand on Nestle single-serve capsules for coffee machines.

USE OF PROCEEDS

	If Target Offering Amount Sold	If Maximum Offering Amount Sold
Total Proceeds	\$10,000.00	\$1,070,000.00
Less: Offering Expenses	\$800.00	\$85,600.00
Net Proceeds	\$9,200.00	\$984,400.00
Use of Net Proceeds		
Inventory Purchases	\$0.00	\$500,000.00
Marketing Development	\$0.00	\$25,000.00
Product Marketing	\$0.00	\$90,000.00
Capital Marketing	\$0.00	\$90,000.00
Social Media Ads	\$1,000.00	\$50,000.00
PR - Services	\$1,500.00	\$20,000.00
Social Media Management	\$0.00	\$10,000.00
New Offering/Amendment	\$0.00	\$10,800.00
Working Capital	\$6,700.00	\$188,600.00
Total Use of Net Proceeds	\$9,200.00	\$984,400.00

*Use of Net Proceeds may be affected by category, as the Company has a robust plan for raising additional Capital from sources other than this Offering. In such an event, as determined by the Board, such additional funds may be allocated to fund part or entirely, one or more of the categories reflected above prior to the receipt of funds from this Offering. In such an event, the funds received from this Offering will be reallocated as directed by the Board, should all categories be funded by other sources, any remainder from this Offering shall be applied to the "Working

Capital" category.

We are seeking to raise a minimum of \$10,000 (target amount) and up to \$1,070,000 (overallotment amount) in this offering through Regulation Crowdfunding.

Irregular Use of Proceeds

The Company will incur Irregular Use of Proceeds that may include but are not limited to the following over \$1,000: Vendor payments and salary made to one's self, a friend or relative; Any expense labeled "Administration Expenses" that is not strictly for administrative purposes; Any expense labeled "Travel and Entertainment"; Any expense that is for the purposes of inter-company – “related party” debt, back or current payments. Further, the Company being a Start-Up business with no assets, cash flow or transactional history is unable to establish conventional credit. The Company has developed and will expand what it refers to as “Private Credit Facility (PCF)” defined for accounting and operational purposes as “PCF Debit and Credit Transactions” received from or payable to; vendors, investors, organizations, related parties, and others, who may provide effectively credit and/or funds in kind to the Company, as need from time to time, requiring repayment in relatively short time periods. Depending on timing such repayments may come from and become part of the use of proceeds.

REGULATORY INFORMATION

Disqualification

No disqualifying event have been recorded in respect to the company or its officers or directors.

Compliance failure

The company has not previously failed to comply with Regulation CF. Annual

Report

The company will make annual reports available at www.LLLBusa.com/Public Documents/ in the section labeled Accounting. The company will make annual reports available on its website and be available within 120 days of the end of the issuer's most recent fiscal year.

EXHIBIT B TO FORM C

FINANCIAL STATEMENTS AND INDEPENDENT ACCOUNTANT'S REVIEW
FOR Locking Line Barriers Corporation dba WATERBLOCKS

[See attached Exhibits]

TABLE OF CONTENTS

<u>Description</u>	<u>Page</u>
Independent Accountant Review Report	3
Profit & Loss Statement	4
Balance Sheet	5
Statement of Cashflows	6
Statement of Shareholders' Equity	7
Notes to Accompanied Financial Statements	8-13

INDEPENDENT ACCOUNTANT REVIEW REPORT

To the Management of LOCKING LINE BARRIERS CORPORATION

We have reviewed the accompanying consolidated financial statements of LOCKING LINE BARRIERS CORPORATION ("The Company"), which comprise the Balance Sheet as of December 31, 2020, and December 31, 2019 and the related Profit & Loss Statements, Statements of Shareholders' Equity, and Statements of Cashflows for the periods then ended, and the related notes to the financial statements. A review includes primarily applying analytical procedures to management's financial data and making inquiries of Company management. A review is substantially less in scope than an audit, the objective of which is the expression of an opinion regarding the financial statements taken as a whole. Accordingly, we do not express such an opinion.

Management's Responsibility for the Consolidated Financial Statements

Management is responsible for the preparation and fair presentation of the financial statements in accordance with accounting principles generally accepted in the United States of America (US GAAP); this includes the design, implementation, and maintenance of internal control relevant to the preparation and fair presentation of the financial statements that are free from material misstatement whether due to fraud or error.

Accountant's Responsibility

Our responsibility is to conduct the review engagement in accordance with Statements on Standards for Accounting and Review Services promulgated by the Accounting and Review Services Committee of the AICPA. Those standards require us to perform procedures to obtain limited assurance as a basis for reporting whether we are aware of any material modifications that should be made to the financial statements for them to be in accordance with accounting principles generally accepted in the United States of America. We believe that the results of our procedures provide a reasonable basis for our conclusion.

Accountant's Conclusion

Based on our review, we are not aware of any material modification that should be made to the accompanying consolidated financial statements in order for them to be in conformity with accounting principles generally accepted in the United States of America.



Omar Almuaini, CPA

Naperville, IL
July 9, 2021



LOCKING LINE BARRIERS CORPORATION
PROFIT & LOSS STATEMENT (UNAUDITED)
FOR THE YEARS ENDED DECEMBER 31, 2020 & 2019

	<u>2020</u>	<u>2019</u>
Revenue		
Revenue	\$ -	\$ -
Total Revenue	-	-
Cost of Sales	-	-
Gross Profit	-	-
Operating Expense		
Management Fees	299,000	131,100
Supplies & Materials Expense	3,000	3,500
Dues & Subscriptions	2,000	-
Bank Fees	1,235	1,583
Total Operating Expenses	305,235	136,183
Net Income From Operations	(305,235)	(136,183)
Other Income (Expense)		
Total Other Income (Expense)	-	-
Net Income Before Provision for Income Tax	(305,235)	(136,183)
Provision for Income Taxes	-	-
Net Income (Loss)	<u>\$ (305,235)</u>	<u>\$ (136,183)</u>

See Independent Accountant's Review Report and accompanying notes, which are an integral part of these financial statements.

LOCKING LINE BARRIERS CORPORATION
BALANCE SHEET (UNAUDITED)
AS OF DECEMBER 31, 2020 & 2019

	<u>12/31/20</u>	<u>12/31/19</u>
<u>ASSETS</u>		
CURRENT ASSETS		
Cash and Cash Equivalents	\$ 11,053	\$ 27,593
Prepaid Expenses	-	3,000
Offering Proceeds Receivable	17,327	9,846
Prepaid Expenses	4,000	-
TOTAL CURRENT ASSETS	32,380	40,439
NON-CURRENT ASSETS		
Patent	10,000	10,000
TOTAL NON-CURRENT ASSETS	10,000	10,000
TOTAL ASSETS	42,380	50,439
<u>LIABILITIES AND OWNER'S EQUITY</u>		
CURRENT LIABILITIES		
Loan Due to Shareholder	-	11,000
TOTAL CURRENT LIABILITIES	-	11,000
NON-CURRENT LIABILITIES		
TOTAL NON-CURRENT LIABILITIES	-	-
TOTAL LIABILITIES	-	11,000
OWNER'S EQUITY		
Common Stock - APIC	590,838	265,453
Preferred Stock - APIC	20,000	-
Contra-Equity Offering Cost	(68,273)	(31,064)
Retained Earnings (Deficit)	(194,950)	(58,767)
Net Income (Loss)	(305,235)	(136,183)
TOTAL SHAREHOLDERS' EQUITY	42,380	39,439
TOTAL LIABILITIES AND SHAREHOLDERS' EQUITY	\$ 42,380	\$ 50,439

See Independent Accountant's Review Report and accompanying notes, which are an integral part of these financial statements.

LOCKING LINE BARRIERS CORPORATION
STATEMENT OF CASHFLOWS (UNAUDITED)
FOR THE YEARS ENDED DECEMBER 31, 2020 & 2019

	<u>2020</u>	<u>2019</u>
OPERATING ACTIVITIES		
Net Income	\$ (305,235)	\$ (136,183)
Non-Cash Adjustments		
Increase in Prepaid Expenses	(4,000)	-
Shares issued in exchange for services	-	-
Decrease in Prepaid Expenses	3,000	-
NET CASH PROVIDED (USED) BY OPERATING ACTIVITIES	<u>(306,235)</u>	<u>(136,183)</u>
INVESTING ACTIVITIES		
Patent acquisition costs	-	(10,000)
NET CASH PROVIDED (USED) BY INVESTING ACTIVITIES	<u>-</u>	<u>(10,000)</u>
FINANCING ACTIVITIES		
Proceeds Common Stock Issuance	325,385	175,816
Proceeds Preferred Stock Issuance	10,000	-
Offering Proceeds Receivable	(7,481)	(9,846)
Contributions from Founder	-	2,407
Loan Due to Shareholder	(1,000)	11,000
Offering costs	(37,209)	(5,640)
NET CASH PROVIDED (USED) BY FINANCING ACTIVITIES	<u>289,695</u>	<u>173,737</u>
NET INCREASE (DECREASE) IN CASH	(16,540)	27,554
CASH AT BEGINNING OF PERIOD	27,593	39
CASH AT END OF PERIOD	\$ 11,053	\$ 27,593

See Independent Accountant's Review Report and accompanying notes, which are an integral part of these financial statements.

LOCKING LINE BARRIERS CORPORATION
STATEMENT OF SHAREHOLDERS' EQUITY (UNAUDITED)
AS OF DECEMBER 31, 2020 & 2019

	Opening Equity Balance	Yearly Changes	Total
Balance, December 31, 2018	\$ 3,039	\$ -	\$ 3,039
Net Income for the period ending December 31, 2019	-	(136,183)	(136,183)
Equity Contributions (Distributions)	-	172,583	172,583
Balance, December 31, 2019	\$ 3,039	\$ 36,400	\$ 39,439
	Opening Equity Balance	Yearly Changes	Total
Balance, December 31, 2019	\$ 39,439	\$ -	\$ 39,439
Net Income for the period ending December 31, 2020	-	(305,235)	(305,235)
Equity Contributions (Distributions)	-	308,176	308,176
Balance, December 31, 2020	\$ 39,439	\$ 2,941	\$ 42,380

See Independent Accountant's Review Report and accompanying notes, which are an integral part of these financial statements.

LOCKING LINE BARRIERS CORPORATION
NOTES TO FINANCIAL STATEMENTS
For The Years Ended December 31, 2020 & 2019

NOTE A – ORGANIZATION AND NATURE OF ACTIVITIES

Locking Line Barriers Corporation (“The Company”) is a corporation organized on October 10, 2015 under the laws of Colorado under the name of Locking Line Barriers and does business under the trade name WaterBlocks. The Company changed its name from Locking Line Barriers to Locking Line Barriers Corporation on February 12, 2018. The Company was formed to market and distribute the WaterBlocks product line.

As of December 31, 2020, the Company has not commenced planned principal operations nor generated revenue. The Company’s activities since inception have consisted of formation activities and capital raising. Once the Company commences its planned principal operations, it will incur significant additional expenses. The Company is dependent upon additional capital resources for the commencement of its planned principal operations and is subject to significant risks and uncertainties; including failing to secure funding to operationalize the Company’s planned operations or failing to profitably operate the business.

NOTE B – SUMMARY OF SIGNIFICANT ACCOUNTING POLICIES

Basis of Presentation

The accompanying financial statements have been prepared in accordance with accounting principles generally accepted in the United States of America (“US GAAP”). As a result, the Company records revenue when earned and expenses when incurred. The Company has adopted the calendar year as its basis of reporting.

Use of Estimates

The preparation of financial statements, in conformity with accounting principles generally accepted in the United States of America requires management to make estimates and assumptions that affect the reported amounts of assets and liabilities, and the disclosures of contingent assets and liabilities and other items, as well as the reported revenues and expenses. Actual results could differ from those estimates.

Cash and Cash Equivalents

Cash and any cash equivalents include all cash balances, and highly liquid investments with maturities of three months or less when purchased.

Stock Subscription Receivable

The Company records stock issuances at the effective date. If the subscription is not funded upon issuance, the Company records a stock subscription receivable as an asset on the balance sheet.

LOCKING LINE BARRIERS CORPORATION
NOTES TO FINANCIAL STATEMENTS
For The Years Ended December 31, 2020 & 2019

NOTE B – SUMMARY OF SIGNIFICANT ACCOUNTING POLICIES (cont.)

Intangible Assets

The Company capitalizes costs related to maintaining and filing patents, copyrights, and trademark applications and commences amortization over a patent's estimated useful life, typically 17 years, when a patent is successfully filed. During 2020 and 2019, the Company capitalized \$0 and \$5,000, respectively, in patent, copyright, and trademark related costs, resulting in intangible assets of \$10,000 as of both December 31, 2020 and 2019, respectively. Amortization expense has not recorded as the patent is pending as of the date these financial statements.

Fair Value of Financial Instruments

Financial Accounting Standards Board ("FASB") guidance specifies a hierarchy of valuation techniques based on whether the inputs to those valuation techniques are observable or unobservable. Observable inputs reflect market data obtained from independent sources, while unobservable inputs reflect market assumptions. The hierarchy gives the highest priority to unadjusted quoted prices in active markets for identical assets or liabilities (Level 1 measurement) and the lowest priority to unobservable inputs (Level 3 measurement). The three levels of the fair value hierarchy are as follows:

- Level 1 - Unadjusted quoted prices in active markets for identical assets or liabilities that the reporting entity has the ability to access at the measurement date. Level 1 primarily consists of financial instruments whose value is based on quoted market prices such as exchange-traded instruments and listed equities.
- Level 2 - Inputs other than quoted prices included within Level 1 that are observable for the asset or liability, either directly or indirectly (e.g., quoted prices of similar assets or liabilities in active markets, or quoted prices for identical or similar assets or liabilities in markets that are not active).
- Level 3 - Unobservable inputs for the asset or liability. Financial instruments are considered Level 3 when their fair values are determined using pricing models, discounted cash flows or similar techniques and at least one significant model assumption or input is unobservable.

As of December 31, 2020 and 2019, the carrying amounts of the Company's financial assets and liabilities reported in the balance sheets approximate their fair value.

Deferred Offering Costs

The Company complies with the requirement of FASB ASC 340-10-S99-1. Prior to the completion of the offering these costs are capitalized as deferred offering costs on the balance sheet. The deferred offering costs are charged to stockholders' equity upon the completion of the offering.

LOCKING LINE BARRIERS CORPORATION
NOTES TO FINANCIAL STATEMENTS
For The Years Ended December 31, 2020 & 2019

NOTE B – SUMMARY OF SIGNIFICANT ACCOUNTING POLICIES (cont.)

Income Taxes

The Company uses the liability method of accounting for income taxes as set forth in ASC 740, Income Taxes. Under the liability method, deferred taxes are determined based on the temporary differences between the financial statement and tax basis of assets and liabilities using tax rates expected to be in effect during the years in which the basis differences reverse. A valuation allowance is recorded when it is unlikely that the deferred tax assets will be realized.

The Company assesses its income tax positions and records tax benefits for all years subject to examination based upon its evaluation of the facts, circumstances and information available at the reporting date. In accordance with ASC 740-10, for those tax positions where there is a greater than 50% likelihood that a tax benefit will be sustained, our policy is to record the largest amount of tax benefit that is more likely than not to be realized upon ultimate settlement with a taxing authority that has full knowledge of all relevant information. For those income tax positions where there is less than 50% likelihood that a tax benefit will be sustained, no tax benefit will be recognized in the financial statements. The Company has determined that there are no material uncertain tax positions.

The Company accounts for income taxes with the recognition of estimated income taxes payable or refundable on income tax returns for the current period and for the estimated future tax effect attributable to temporary differences and carryforwards. Measurement of deferred income items is based on enacted tax laws including tax rates, with the measurement of deferred income tax assets being reduced by available tax benefits not expected to be realized in the immediate future. The Company estimates it will have net operating loss carryforwards of \$500,185 and \$194,950 as of December 31, 2020 and 2019, respectively. The Company pays federal and Colorado income taxes at a combined effective rate of approximately 25% and has used this effective rate to derive net deferred tax assets of \$123,334 and \$48,070 as of December 31, 2020 and 2019, respectively, resulting from its net operating loss carryforward. Due to uncertainty as to the Company's ability to generate sufficient taxable income in the future to utilize the net operating loss carryforwards, the Company has recorded a full valuation allowance to reduce the net deferred tax asset to zero.

No tax returns have been filed since inception. The Company may be subject to an indeterminate amount of late filing fees due to its delinquent tax returns. All tax periods since inception remain open to examination by the taxing jurisdictions to which the Company is subject.

Advertising Expenses

The Company expenses advertising costs as they are incurred.

Commitments and Contingencies

The Company may be subject to pending legal proceedings and regulatory actions in the ordinary course of business. The results of such proceedings cannot be predicted with certainty, but the Company does not anticipate that the final outcome, if any, arising out of any such matter will have a material adverse effect on its business, financial condition or results of operations. As of December 31, 2020 and 2019, the Company has not reported any lawsuit or known plans of litigation by or against the Company.

LOCKING LINE BARRIERS CORPORATION
NOTES TO FINANCIAL STATEMENTS
For The Years Ended December 31, 2020 & 2019

NOTE B – SUMMARY OF SIGNIFICANT ACCOUNTING POLICIES (cont.)

Due to Related Party

During 2019, the Company's CEO advanced the Company \$11,000. This advance bears no interest and is payable on demand. In 2020, the Company made cash payments of \$1,000 and issued 1,000 shares of Preferred Stock in exchange for the remaining \$10,000 payable. As of December 31, 2020, the advance totaled \$0.

NOTE C – GOING CONCERN

The accompanying financial statements have been prepared on a going concern basis, which contemplates the realization of assets and the satisfaction of liabilities in the normal course of business. The Company is a business that has not yet generated revenue or profits, has sustained net losses of \$305,235 and \$136,183 during the years ended December 31, 2020 and 2019, respectively, has negative cash flows from operations, has limited liquid assets with just \$11,053 of cash held as of December 31, 2020, and has an accumulated deficit of \$500,185 as of December 31, 2020.

The Company's ability to continue as a going concern in the next twelve months is dependent upon its ability to obtain capital financing from investors sufficient to meet current and future obligations and deploy such capital to produce profitable operating results. No assurance can be given that the Company will be successful in these efforts. These factors, among others, raise substantial doubt about the ability of the Company to continue as a going concern for a reasonable period of time. The balance sheet does not include any adjustments relating to the recoverability and classification of recorded asset amounts or the amounts and classification of liabilities that might be necessary should the Company be unable to continue as a going concern.

NOTE D – STOCKHOLDERS' EQUITY

Common Stock

Under the articles of incorporation, the total number of common shares of stock that the Corporation shall have authority to issue is twenty million (20,000,000), zero par value per share. Of the twenty million authorized shares, 8,500,000 shares have been designated as Class A Unrestricted Voting Common Stock, 2,500,000 shares as Class B Restricted Non-Voting Common Stock, the remaining 9,000,000 are currently undesignated common stock.

Class A and Class B common stockholders have identical rights, with the exception of voting rights, to which Class B stockholders have no voting rights.

LOCKING LINE BARRIERS CORPORATION
NOTES TO FINANCIAL STATEMENTS
For The Years Ended December 31, 2020 & 2019

NOTE D – STOCKHOLDERS' EQUITY (cont.)

Common Stock (cont.)

In 2020, the Company issued 48,101 shares of Class B Non-Voting Common Stock at \$1.00 per share resulting in gross proceeds of \$48,101. In 2020, the Company raised \$277,284 through issuance of its Class B Non-Voting Common Stock pursuant to an offering under Regulation Crowdfunding, where 138,642 shares were issued at \$2.00 per share. As of December 31, 2020 there was \$17,327 of subscription receivables related to these issuances.

In 2019, the Company issued 42,500 shares of Class B Non-Voting Common Stock at \$1.00 per share resulting in gross proceeds of \$42,500. In 2019, the Company raised \$133,316 through issuance of its Class B Non-Voting Common Stock pursuant to an offering under Regulation Crowdfunding, where 66,658 shares were issued at \$2.00 per share. As of December 31, 2019 there was \$9,846 of subscription receivables related to these issuances.

Treasury Stock

The Company issued itself shares of common stock as treasury stock. Common stock issuances in 2020 and 2019 were out of the treasury stock balances.

Of the original 8,500,000 shares of Class A Voting Common Stock, 7,500,000 shares are held by outside shareholders and 1,000,000 shares remain in Corporate Treasury, as of December 31, 2020.

Of the original 2,500,000 shares of Class B Non-Voting Common Stock, 2,109,065 shares are held by outside shareholders and 390,935 shares remain in Corporate Treasury, as of December 31, 2020.

Preferred Stock

In 2020, the Company issued 2,000 shares of Preferred stock at \$10 per share resulting in gross cash proceeds of \$10,000 and settlement of a loan of \$10,000, resulting in an increase of Preferred Stock APIC of \$20,000. Preferred stockholders have no voting rights until converted to Common Shares, as stated in the offering and confirmed at the time of issue. Preferred stock has liquidation preferences in the case of a liquidation of the Company under the terms of the articles of incorporation.

On February 8, 2020, the Board of Directors authorized the CEO of the Company to amended and restate its Articles of Incorporation to authorize a total of 100,000,000 shares of Common Stock and 100,000,000 shares of Common Stock in the future as determined to be in the best interest of the Company by the CEO, which has not been implemented as of the date of this document.

LOCKING LINE BARRIERS CORPORATION
NOTES TO FINANCIAL STATEMENTS
For The Years Ended December 31, 2020 & 2019

NOTE E – RELATED PARTY TRANSACTIONS

Related Party Management Fees

The Company has an informal management agreement with Strategic Solutions Team, Inc. ("SST"), which has not been formalized or memorialized. SST is wholly owned by the CEO of the Company. The agreement is for SST to manage and facilitate all corporate and business needs and activities of the Company until such time the Company has the resources and begins operations on its own. For the years ended December 31, 2020 and 2019, the Company paid SST \$299,000 and \$131,100 respectively.

Related Party Global Distribution Agreement

Great American Holdings, Inc. holds all intellectual property, manufacturing, sales, and distribution rights to the WaterBlocks products. The Company offered to acquire the Exclusive Global Marketing Rights under a license agreement. The Company at the time, barren of cash, offered Great American Holdings, Inc. a Royalty of 3% of the product(s) gross sales receipts (as defined in the agreement) and 3% of product gross rental revenue, and further a substantial block of the Company's Common Class A voting Stock in exchange for the License to the Exclusive Global Marketing Rights, which was accepted and became effective immediately.

On October 27, 2017, the License and Global Distribution Agreement was entered into between the Company and Great American Holdings, Inc., which is a related party as the CEO of the Company and is its controlling shareholder. The agreement has a term of 20 years, commenced on October 27, 2017, and renews automatically for a like period in perpetuity, absent any objection by either party, upon 30 days written notice from the objecting party to the other.

NOTE F – CONCENTRATIONS OF RISK

Financial instruments that potentially subject the Company to credit risk consist of cash and cash equivalents. The Company places its cash and any cash equivalents with a limited number of high-quality financial institutions and does not exceed the amount of insurance provided on such deposits.

NOTE G – SUBSEQUENT EVENTS

Crowdfunding Campaign

During 2021, the Company has raised \$80,396 through its Regulation CF offering.

Management's Evaluation

Management has evaluated subsequent events through July 9, 2021, the date on which the financial this report was available to be issued. Management has determined that none of the events occurring after the date of the Financial Statements as of December 31, 2020 and 2019 through the date of Management's review substantially affect the amounts and disclosure of the accompanying financial statements.

EXHIBIT C TO FORM C

PROFILE

SCREENSHOTS

[See attached]

Locking Line Barriers Corporation dba WaterBlocks

Help Save Lives, Communities and the Environment!



54% funded (of minimum target)



\$574,432 <i>amount committed</i>	\$1070k <i>funding goal</i>
Regulation CF <i>exemption used</i>	\$18,000,000 <i>pre money valuation</i>
\$200.00 <i>min investment</i>	1258 <i>investors</i>

Security Type

----- Common Class B Shares Non-Voting -----

Bonus

Perks Packages List

\$200+ Investment - a Digital Certificate of Ownership Replica - (bragging rights)
Every Investor receives a Digital Certificate.

Investors over \$500 receive the one applicable perk listed below:

\$500+ Investment - Lunch On Us
(*\$25 Outback Steakhouse Gift Card*)

\$1,000+ Investment - Dinner On Us
(*\$60 Outback Steakhouse Gift Card*)

\$5,000+ Investment - a Las Vegas Getaway*
(*Hotel for 2 people for 3-days/2-nights*)

\$10,000+ Investment - a Grand Las Vegas Getaway*
(*Hotel for 2 people for up to 4-days/3-nights - plus 2 Show Tickets & Dinner with LLB CEO*)

\$15,000+ Investment - a Reno VIP Getaway*
(*Hotel for 2 people for 4-days/3-nights, show tickets and Dinner with LLB CEO*)
* Airfare not included

\$20,000+ Investment - a Grand Reno VIP Getaway
(*Hotel for 2 people for 5-days/4-nights, Domestic Airfare, show tickets and a Golf/Ski Day, plus Dinner with LLB CEO*)

\$30,000+ Investment - a Colorado Concierge Vacation
(*Hotel for 2 people for 4-days/3-nights, plus Domestic Airfare, Ground Transportation, Dinner with LLB CEO, and a Custom Entertainment Package including either sporting event, skiing or touring with Concierge Assistance throughout your stay*)

\$50,000+ Investment - a Grand Weeklong Colorado Concierge Vacation
(*Hotel for 2 people for 7-days/6-nights, plus Domestic Airfare, Ground Transportation, Dinner with LLB CEO and a Custom Entertainment Package including your choice of sporting event, skiing, or touring with Concierge Assistance throughout your stay*)

Please also note:

You may elect to donate the monetary equivalent of your perk to the Disaster Support Foundation or any other charity of your choosing.

*All perks occur after the offering is completed.

Pitch

Who are we

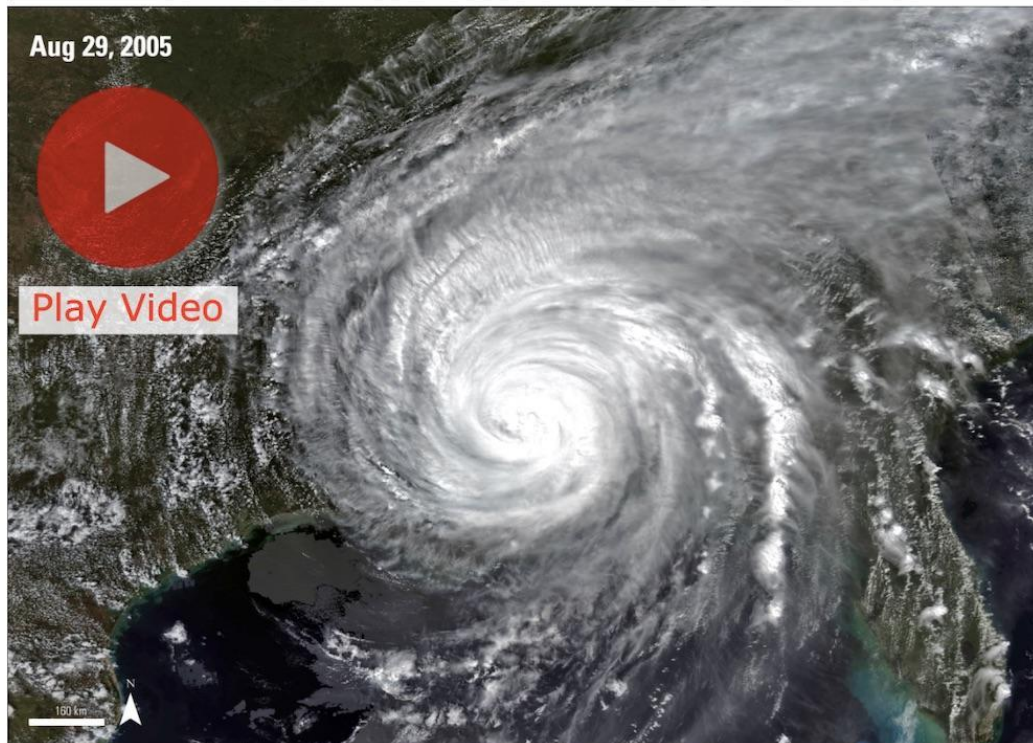

WaterBlocks™ is a registered TradeMark and dba (alternate corporate identity) of Locking Line Barriers Corporation.

Locking Line Barriers is proud to introduce a revolutionary product line that's primed to set a new bar in large-scale flood protection, WaterBlocks™, along with our new Digital Barrier Sharing Network.

Flooding affects more and more Americans every year - and yet, we continue to rely on inadequate systems for managing, redirecting, and stopping the onslaught of floodwaters.

Problem

"Locking Line Barriers was founded with the mission to provide a superior flood protection system to help save lives, our communities, and our environment."



The Problem: How Do You Stop a Flood

You Don't!

All you can do is divert the floodwaters and energy elsewhere.

Flooding is a growing concern for millions of people and municipalities nationwide. Flooding is affecting more and more Americans every year. And yet, we continue to rely on ancient and inadequate systems for managing, redirecting, and stopping the onslaught of floodwaters.

The Current Tools:



Concrete Walls

Jersey Barriers

Sandbags

Anything Handy

The Current Status:

There are No New Comprehensive Tools
To battle Flooding Destruction available!

Flooding is a growing concern for millions of people and municipalities nationwide. Flooding is affecting more and more Americans every year. And yet, we continue to rely on ancient and inadequate systems for managing, redirecting and stopping the onslaught of floodwaters.

So what can stand between
a community and a flood?

Not Much Until Now!

Solution

New Solutions Have Arrived:

WaterBlocks Multiuse Flood Control Barrier Systems!

WaterBlocks™ The Design

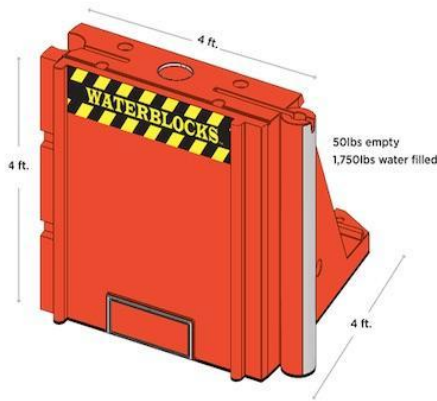

Sized Perfectly:

- ✓ Maximize Transport and Warehousing Space
- ✓ Lightweight for ease of handling

Versatile:

- ✓ Change Wall Assembly Direction as required
- ✓ Control Flooding, Traffic, Crowds & Hazardous Waste

Customizable:

- ✓ Efficiently Lock & Seal Barriers into any configuration
- ✓ Stackable
- ✓ Self-filling in flood use

Rapidly-Deployable:

- ✓ Easily lifted & moved. 2 men, 2-3 hours installation
- ✓ 104 barriers for a total of 416 Linear feet per (1) 53' Trailer
- ✓ Quick Release Device to eliminate lifting and permit rapid deployment of units

DURABLE & COST-EFFECTIVE:

- ✓ Steel-Reinforced Polyethylene Plastic
- ✓ 20 Year Life - REUSABLE and Recyclable

WaterBlocks™ Our Solution Part 1

WaterBlocks™ are our proprietary line of steel-reinforced polyethylene blocks to create a rapidly-deployable wall of

Barrier Protection.

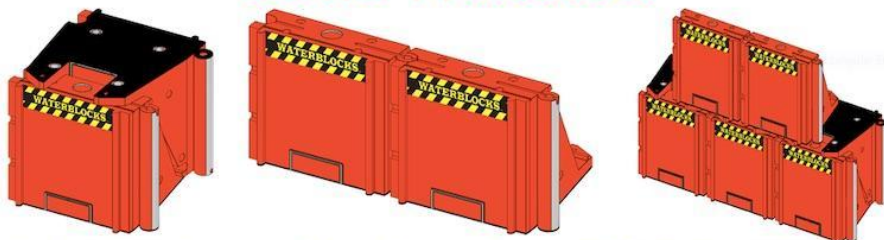

Shipping Set

Deployed

Wall Stack

WaterBlocks™ Asset Management & Barrier Sharing Network

WaterBlocks™ Our Solution Part 2

The Barrier Sharing Network

Summary

The Concept:

A Digital (Uber like) Localized Network For **WaterBlocks** and other Disaster Mitigation and Recovery related Equipment, Materials and Services. Solutions rapidly deployable and available to Emergency Planners and Responders anywhere and everywhere as and when needed.

As No organization including **FEMA** has the capacity to own and inventory all the different resources necessary to meet all the needs and demands required in a disaster.

Potential Users:

Clients; Municipalities, any and all government agencies and jurisdictions, large to major Corporations and local Disaster Support related companies.

Partners; any and all entities can be a vendor / partner with us and join the network, providing Disaster Mitigation and Recovery related Equipment of all kinds, Materials and Services, even WaterBlocks competitors.

Potential Partner Assets:



There are countless firms that are too small for FEMA and yet can be a provider if emergency responders can find them. We intend to make that happen.

Flooding is a unique disaster in terms of how quickly it strikes - with little notice for preparation. A means to Rapidly Respond, locate the tools, resources and solutions readily, and then Rapidly Deploy them is the only logical solution.

Communities under the threat of floods are begging to be better prepared with adequate barrier protection. With our rigorous background in industrial manufacturing, construction and logistical operations, we've gone ahead and envisioned an innovative, forward-thinking solution - the Barrier Sharing Rental Network (think Uber like).

Achievement & Traction

Our Trailers can be Included (upon request):



Just look at what can fit inside a single semi-trailer truck:

- 96 WaterBlocks™ Main Units
- 8 WaterBlocks™ Corner Turning Units

That's 104 barriers providing 416 linear feet of heavy-duty, customizable protection packed in a 53' trailer!

And while that's a standard configuration, any grouping of barriers may be accommodated as the need arises.

the occasional local vendor.

WaterBlocks™ have many useful applications including crowd - traffic safety and control, construction site protection, natural resource protection and conservation, and more.

The Barrier Sharing Rental Network is a digital system whereby WaterBlocks™ can be rapidly transported on short notice as a cost-effective response to pending flood threats - anywhere in the US or around the globe. Because when it comes to mitigating flood damage and destruction, as delivery of large quantities of barriers on short notice is the key.

- We anticipate that our primary stage objectives center around the sale of WaterBlocks™ themselves will generate the revenue necessary to support our continued future growth.
- The establishment of the Barrier Sharing Network offers WaterBlocks a sustainable, long-term (20+ years) source of revenue and ever-expanding rental and licensing opportunities.
- The Barrier Sharing Rental Network is an intangible asset consisting of the software platform (not yet built) - which may ultimately be patentable in its own right - and management thereof.

We will seek to secure sponsorship from major corporations, governmental bodies, private foundations and non-profit organizations to provide the acquisition costs of large numbers of truckload inventory. We are a capital intensive company and will always be raising capital to expand our barrier inventory. Our inventory base will provide thousands of linear feet of WaterBlocks™ Barriers that can be instantly assigned, transported and deployed to participating municipalities, counties and states in need of flood protection or any other WaterBlocks™ application.

Utilizing our new Barrier Sharing Network, a forward-thinking revolutionary solution enables communities and emergency responders to have timely access to WaterBlocks™ solutions, on a cost-effective, as needed basis.

Flooding and other Disasters strike with little notice, but WaterBlocks™ empowers municipalities, governmental agencies, and NGO's and emergency responders to be better equipped with new 'on call' Tools and Services to protect lives, communities and our environment.

Invest in WaterBlocks™ dba Locking Line Barriers Corporation with confidence as we prepare to go to market with our revolutionary WaterBlocks™ product line and related services. Funds from this raise will be used to support our efforts to; begin operations, recruit staff, create inventory, expand marketing, promotions, and product line sales at trade shows as well as promotional events with municipalities across the country and globally, research and development, and general operating expenses.

Market

The BENEFIT

*"For every \$1 spent on Disaster Mitigation,
\$7 are saved in Disaster Recovery Costs"
The Denver Post and (Multihazard Mitigation Council) (2017)*

To examine the current market viability of WaterBlocks™, Locking Line Barriers commissioned a detailed study looking at the market acceptance, need and overall demand for rapidly-deployable flood protection and multi-use barrier systems.

Additional focus was spent on means of access including whether the assets are rented through a web-based asset and cost-sharing network rather than outright purchased per standard convention.

Since the WaterBlocks™ target market is the emergency authorities and responders of municipalities, government agencies and NGO's, research consisted of a nationwide sampling of 36 randomly-selected jurisdictions.

Our research resulted in these key findings:

- Market need & demand for flood barriers far exceeds the current availability of a sufficient supply
- Until WaterBlocks™ are brought to market, the need & demand will remain unfulfilled for the foreseeable future

It would take more than 800 Truckloads of WaterBlocks™ (806 to be exact, with 63.5 miles of barriers) to fulfill the demand for flood barrier systems - and that's just for the 36 respondents surveyed.

At the currently-discounted MSRP cost of \$130,000 per truckload, LLB sales would be \$104,780,000 per Truckload for the 36 respondents polled so far. 800 Truckloads would cost a little less than \$120M.

Fact is - once it starts raining, it's already too late. Communities need a faster, more reliable solution to this looming threat. Most all flood control tools currently available in the US are heavy, not easily moveable or deployable and typically permanent once constructed.

What makes WaterBlocks™ so special is their unique design, which allows them to be both rapidly-deployed and efficiently-assembled and removed.

Over the past three years we have had extensive discussions with municipalities and various governmental agencies reflecting a common theme professed by all: 'an additional source of flood barrier supply and support is needed'. Our communities' needs can't just rely on FEMA, NGO's and

Product Demand Analysis from our Market Survey

WaterBlocks™ The Demand

Locking Line Barriers Corporation commissioned a detailed study to evaluate: market acceptance, need and overall demand for rapidly deployable flood protection and multi-use barrier systems. The research resulted in these key findings:

- Market need & demand for flood barriers far exceeds the current availability of a sufficient supply
- Until WaterBlocks™ saturate the market, the need & demand will remain unfulfilled for the foreseeable future.

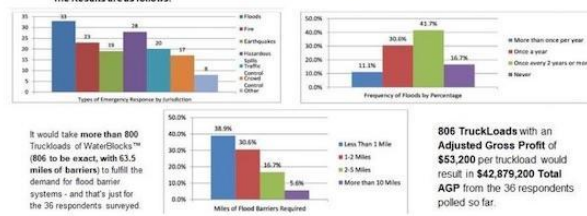

To examine the current market viability of WaterBlocks™, Locking Line Barriers commissioned a detailed study looking at the market acceptance, need and overall demand for rapidly-deployable flood protection and multi-use barrier systems.

Additional focus was spent on means of access including whether the assets are rented through a web-based asset and cost-sharing network rather than outright purchased per standard convention.

Since the WaterBlocks™ target market is the emergency authorities and responders of municipalities, government agencies and NGO's, research consisted of a nationwide sampling of 36 randomly-selected jurisdictions.

Our research resulted in these key findings:

- Market need & demand for flood barriers far exceeds the current availability of a sufficient supply
- Until WaterBlocks™ are brought to market, the need & demand will remain unfulfilled for the foreseeable future

It would take more than 800 Truckloads of WaterBlocks™ (806 to be exact, with 63.5 miles of barriers) to fulfill the demand for flood barrier systems – and that's just for the 36 respondents surveyed.

At the currently-discounted MSRP cost of \$130,000 per truckload, LLB sales would be \$104,780,000 per Truckload for the 36 respondents polled so far. 800 Truckloads would cost a little less than \$120M.

Competition

There are, of course, a number of existing plastic barriers on the market – most being designed for traffic safety and control, their uses are limited, rendering them useless for flood control or liquid overflow management.



Business Model

We intend to formulate a worldwide licensing program that enables WaterBlocks™ – or a variant thereof – to be sold and distributed overseas. In fact, we have already received licensing inquiries from Mexico and Holland, however our primary objectives at this time are product sales and the establishment of the Barrier Sharing Network (BSN) in the United States.

WaterBlocks initial sales efforts are focused on six key target markets:

- Product Sales to government agencies and municipalities
- Product Sales to major corporations in the Construction and Petroleum industries
- Distributorship Development and Expansion domestically and globally
- Sponsorship sales to major Corporate Social Responsibility (CSR) departments for BSN inventory expansion
- Crowdfunding Revenue Sharing Agreement Investments in BSN inventory expansion
- Revenue Sharing Agreement Investment Sales and Grants from Charitable 501c3 organizations for BSN inventory expansion based on the following:

NCCS Home >> NCCS Web Tools >> NCCS Table Wizard

Registered 501(c)(3) Public Charities by IRS Subsection Code (BMF 08/2016 501c3)

SUBSECCD	Number of Registered Organizations	Number of Organizations Filing Form 990 *	Total Revenue Reported on Form 990 *	Assets Reported on Form 990 *	Number of Organizations Filing Form 990-N ** or 990-N ***	Total Number of Organizations Filing Form 990 or 990-N ***
03	1,108,652	371,651	1,851,278,529,038	3,481,204,596,971	385,615	757,266
Total	1,108,652	371,651	1,851,278,529,038	3,481,204,596,971	385,615	757,266

Citation: Internal Revenue Service, Exempt Organizations Business Master File ()
The Urban Institute, National Center for Charitable Statistics, <http://nccs.urban.org/>

Notes:
* Includes organizations that filed financial information on Form 990, 990-EZ or 990-PF within 24 months of the BMF release date, as reported in NCCS Core Files and IRS Business Master Files (excludes 990-N ePostcard filers).
** Includes organizations that reported zero (\$0) revenue and zero assets on a Form 990, 990-EZ, 990-PF and, since 2008, 990-N ePostcard within 24 months of the BMF release date, as reported in NCCS Core Files and IRS Business Master Files.
*** Includes all organizations that filed a Form 990, 990-EZ, 990-PF and, since 2008, 990-N ePostcard within 24 months of the BMF release date, as reported in NCCS Core Files and IRS Business Master Files.

We estimate that \$21 trillion is held by the more than 80,000 non-profit organizations that fall under 501c3 status in the US. NOTE: this is our estimate of the potential participants from the global group as reported in the chart.

With this in mind, we have also established an agreement with the Disaster Support Foundation (DSF), a 501c3 non-profit who will seek grants and donations to acquire and provide WaterBlocks™ for the Barrier Sharing Network for a share of the revenue. This relationship provides potential charitable sponsors with the opportunity to leverage tax-deductible donations for positive social impact affecting countless communities nationwide.

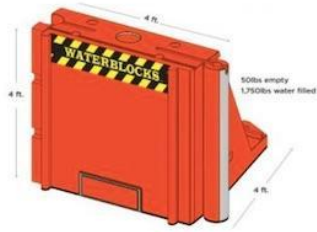

WaterBlocks™ are steel-reinforced, interconnecting plastic units that link together to create a diversionary wall of protection.

WaterBlocks can be DOUBLE STACKED ... (like Legos)

When you NEED 8 FEET of Height Protection

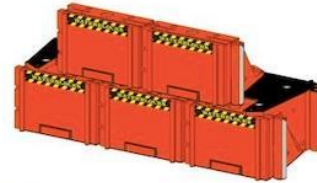

They Have The Strength!
Support Test:
3,500 lbs. of Steel
Dead Weight
No Damage!

Team

Joe Daniluk



Chairman
CEO

Ambassador Sam
Zakheim



Director
Governmental Relations

Scott Saxman



Director
Global Business
Development

Will Hunziker



Director
Patents & Licensing

Steve Tannenbaum



Director
Finance

Stephen Daniluk



Engineering & IT
Manager

VIDEO TRANSCRIPT (Exhibit D)

WaterBlocks Intro-Video Transcript

We have the technology to forecast storms 7 to 14 days in advance.

Within that 10 to 14 day timeframe we don't have the technology to respond to mitigate the damage this caused by these storms. Until now.

My name is Joe Daniluk. I'm president of the Locking Line Barrier Corporation. Allow me to introduce you to a brand new technology. Rapid deployable flood control barrier system that we've trademark under the name of WaterBlocks.

It's a 4 foot cube that when divided in half in a very unique fashion it becomes

two separate pieces, when put together for flood protection, creates a 4-foot wall 8 foot wide and 4-foot tall. It's rapidly deployable. It's easily handled. There is no other product in the market

that does exactly that.

The current tools that are used by municipalities across the country and around the world consists of sandbag walls jersey barriers and then anything else that might be handy.

We decided to commission a market survey. The demand for our product is so large just in this country alone, there is not enough manufacturing facilities in existence to make enough barriers

to meet the entirety of the demand.

Take for example a hospital that sits on a quarter acre square that needs flood control protection to create an island of safety for the building. That's 1 mile of barriers that's needed. And we need ten truck-loads which costs 1.5 million dollars.

That 1.5 million dollar investment can be reused for at least the next 20 years to protect that 1.5 billion dollar hospital complex.

If we did that for just one hospital, what we would need to do for the entire county. And then think about hurricanes, have impacted our coastlines all around our country.

The demand exists without question for our product. We're ready to go to market with the solution to the problem. But what we need is your help. Join with us on our investor team.

So that we can go out and help save communities, lives, property and our environment.

WaterBlocks Product Demo Video Transcript

I'll tell you a little bit about our product how it functions and what it does.

This is a one-ninth scale model. In real life a four foot cube it's four foot by four foot by four foot it weighs in this shape about a hundred pounds now the way we turn it into an eight foot wall.

Originally it was designed to function like this. But we decided that lifting this four feet in the air and then having to drop it down that slot might be troublesome. So we built this quick- release mechanism. It has its own grab handles and you set it out of the way and pull them apart you don't have to lift them there's no lifting involved.

You can now access the door let the water out, put the lifting mechanism back in place, put them back together and reload them in the truck.

We use a special resin that will give us a 20 year warranty life from the resin manufacturer themselves.

The question that everyone's had is how do we seal the joint between the two and that's because of a magnetic seal. In the female joint right in that notch and that's what seals the joint so the water doesn't come flowing through between the barriers.

The unique features of this include water doors this is a gravity door when the water comes and it starts to rise it fills the barrier which only weighed fifty pounds it now weighs 1,750 pounds.

If you want to fill it before the flood comes you can use this four inch hole and stick your fire hose in there and let the pumper truck pump the water in and fill it up.

For ease of emptying a sliding door that you can open and let all the water out then fold it back up and put it together. Load them back in the truck and send them on their way they're gone.

And that's all there is to it.

Text

PORTAL SUBSCRIPTION PROCESS (Exhibit E)

Platform Compensation

- As compensation for the services provided by Portal, the issuer is required to pay to Portal a fee consisting of 8% (eight percent) commission based on the dollar amount of securities sold in the Offering and paid upon disbursement of funds from escrow at the time of a closing. The commission is paid in cash.

Information Regarding Length of Time of Offering

- Investment Cancellations: Investors will have up to 48 hours prior to the end of the offering period to change their minds and cancel their investment commitments for any reason. Once within 48 hours of ending, investors will not be able to cancel for any reason, even if they make a commitment during this period.
- Material Changes: Material changes to an offering include but are not limited to: A change in minimum offering amount, change in security price, change in management, material change to financial information, etc. If an issuer makes a material change to the offering terms or other information disclosed, including a change to the offering deadline, investors will be given five business days to reconfirm their investment commitment. If investors do not reconfirm, their investment will be cancelled and the funds will be returned.

Hitting The Target Goal Early & Oversubscriptions

- If the issuer hits its goal early, and the minimum offering period of 21 days has been met, the issuer can create a new target deadline at least 5 business days out. Investors will be notified of the new target deadline via email and will then have the opportunity to cancel up to 48 hours before new deadline.
- Oversubscriptions: In the event of an oversubscription, shares will be allocated at the discretion of the issuer.
- If the sum of the investment commitments does not equal or exceed the target offering amount at the offering deadline, no securities will be sold in the offering, investment commitments will be cancelled and committed funds will be returned.
- If a Portal issuer reaches its target offering amount prior to the deadline, it may conduct an initial closing of the offering early if they provide notice of the new offering deadline at least five business days prior to the new offering deadline (absent a material change that would require an extension of the offering and reconfirmation of the investment commitment). Portal will notify investors when the issuer meets its

target offering amount. Thereafter, the issuer may conduct additional closings until the offering deadline.

Minimum and Maximum Investment Amounts

- In order to invest, to commit to an investment or to communicate on our platform, users must open an account on our Portal and provide certain personal and non- personal information including information related to income, net worth, and other investments.
- Investor Limitations: Investors can be limited in how much they can invest on all crowdfunding offerings during any 12-month period. The limitation on how much they can invest depends on their net worth (excluding the value of their primary residence) and annual income.

EXHIBIT F TO FORM C

ADDITIONAL CORPORATE DOCUMENTS

ARTICLES OF

INCORPORATION OF

Locking Line Barriers

dba

LLB Corporation

KNOW ALL MEN BY THESE PRESENTS: That the undersigned, being a natural person of eighteen years or more, proposes to form a corporation in accordance with the laws of the State of Colorado pursuant to the Colorado Business Corporation Act, and to that end does hereby sign, adopt and deliver to the Secretary of State of Colorado these Articles of Incorporation:

ARTICLE I

Name

The name of the corporation shall be:

LOCKING LINE BARRIERS

dba

LLB

Corporation

ARTICLE II

Period of Duration

This corporation shall exist in perpetuity, from and after the date of filing these Articles of Incorporation with the Secretary of State of Colorado unless dissolved according to law.

ARTICLE III

Registered Office and Registered Agent

The address of the initial registered office of the corporation is 4155 E. Jewell Ave. Suite 610 Denver, Colorado 80222 and the name of the initial registered agent at such address is Joseph Daniluk. Either the registered office or the registered agent may be changed in the manner permitted by law.

ARTICLE IV

Objects and Purposes

The objects and purposes for which the said corporation is organized and the nature of the business to be carried on by it is to engage in any lawful act or activity for which a corporation may be organized under the Colorado Revised Statutes, as amended.

The clauses setforth herein shall be construed as objects, purposes and powers and the matters

expressed in each clause shall be in no way limited by reference or inference from the terms of any other clause, but shall be regarded as independent objects, purposes and powers; the enumeration of specific objects, purposes and powers shall not be construed to limit or restrict in any manner the general powers and rights of the corporation as provided by law, or shall the expression of one object, purpose or power be determined to exclude another, although it be of like nature but not expressed. Further, the purpose shall include the restatement of the original articles of incorporation and reorganization under Colorado Law, as directed by the Board of Directors and approved by the Shareholders.

ARTICLE V

Capital

The aggregate number of shares Capital Stock which this corporation shall have authority to issue is 20,000,000 shares of no par value each, which shares shall be designated "Common Stock," in one or more classes or series, having no par value each, and 20,000,000 shares designated "Preferred Stock," in one or more classes or series, each having no par value or a par value as determined by the Board of Directors.

Authority is vested in the board of directors of the corporation to prescribe, in a resolution providing for the issuance of such shares, the classes, series, the number of each class or series of stock to be issued and the voting powers or no voting powers, designations, preferences, limitations, restrictions and relative rights of each class or series of stock. The corporation shall have one or more classes of shares that together have unlimited voting rights and one or more classes that together are entitled to receive the corporation's net assets upon dissolution.

1. **Voting Rights, Cumulative voting.** Each outstanding share of the classes and series shall be entitled to such voting powers, full or limited, or no voting powers as shall be stated and expressed in the resolution providing for the issue of such stock adopted by the corporation's board of directors. Cumulative voting shall not be allowed in any election by the shareholders of the corporation.

2. **Pre-emptive Rights.** Any holder of shares of the corporation, whether now of hereafter authorized, shall not have the pre-emptive or preferential right to acquire any shares or securities of the corporation, including shares or securities held in the treasury of the corporation. The corporation's board of directors may create and issue warrants, rights or options to purchase any shares of stock of any class, classes or series, whether or not in connection with the issue and sale of any shares of stock or other securities. Shares may be issued with terms which include the option for such stock to be redeemable, convertible, or exchangeable for shares of another class or series of stock of the corporation, at the option of the corporation, the stockholder or another person, or upon the occurrence of a designated event, at such price or rate as shall be stated and expressed in the resolution providing for the issue of such shares.

Dividends. Dividends in cash, property or shares of the corporation may be paid upon the outstanding Capital Stock, excluding any treasury stock held by the corporation, as and when declared by the board of directors, out of funds of the corporation to the extent and in the manner permitted by law.

3. Distribution in Liquidation. Upon any liquidation, dissolution or winding up of the corporation, and after paying or adequately providing for the payment of all its obligations, the remainder of the assets of the corporation shall be distributed, either in cash or in kind, pro-rata to the holders; first to the preferred shareholders, and any remainder then to the common shareholders. The board of directors may, from time to time, distribute to the shareholders in partial liquidation, a portion of its assets, in cash or property, in the manner permitted and upon compliance with limitations imposed by law.

ARTICLE VI

Initial Board of Directors

The number of directors of the corporation and the classifications as to the term of office shall be provided for in the bylaws of the corporation. The initial number of directors shall be one. The name and address of the initial member is Joseph Daniluk 4155 E. Jewell Ave. Suite 610 Denver, Colorado 80222.

ARTICLE VII

Bylaws of the Corporation

The Bylaws may contain any provisions for the regulation and management of the affairs of the corporation not inconsistent with applicable law or these Articles of Incorporation. The initial Bylaws of the corporation shall be adopted by the board of directors. Subject to bylaws, if any, that may be adopted by the stockholders entitled to vote thereon, the power to adopt, alter, amend, or repeal the bylaws or to adopt new bylaws is vested in the board of directors of the corporation.

ARTICLE VIII

Right of Directors to Contract with the Corporation

No contract or other transaction between the corporation and one or more of its directors or any other corporation, firm association, or entity in which one or more of its directors are directors or officers or are financially interested shall be either void or voidable solely because of such relationship or interest or solely because such directors are present at the meeting of the board of directors or a committee thereof which authorizes, approves, or ratifies such contract or transaction.

ARTICLE IX

Corporate Opportunity

The officers, directors and other members of management of this corporation shall be subject to

the doctrine of "corporate opportunities" only insofar as it applies to business opportunities in which this corporation has expressed an interest as determined from time to time by this corporation's board of directors as evidenced by resolutions appearing in the corporation's minutes. Once such areas of interest are delineated, all such business opportunities within such areas of interest which come to the attention of the officers, directors, and other members of management of this corporation shall be disclosed promptly to this corporation and made available to it. The board of directors may reject any business opportunity presented to it and thereafter any officer, director or member of management may avail himself of such opportunity. Until such time as this corporation, through its board of directors, has designated an area of interest, the officers, directors and other members of management of this corporation shall be free to engage in such areas of interest on their own and this doctrine shall not limit the rights of any officer, director or other member of management of this corporation to continue a business existing prior to the time that such area of interest is designated by the corporation. This provision shall not be construed to release any employee of this corporation (other than an officer, director or member of management) from any duties which he may have to this corporation.

ARTICLE X

Eliminating Personal Liability

Officers and directors shall have no personal liability to the corporation or its shareholders for damages for breach of fiduciary duty as an officer or director. This provision does not eliminate or limit the liability of an officer or director for acts or omissions involving intentional misconduct, fraud, a knowing violation of law, or the payment of dividends in violation of any applicable statute.

ARTICLE XI

Indemnification of Officers, Directors and Others

The corporation may indemnify any person, his heirs, executors and administrators entitled to indemnification as provided for in the Colorado Statutes, as revised, who was or is a party or is threatened to be made a party to any threatened, pending, or completed action, suit, or proceeding, whether civil, criminal, administrative, or investigative to the maximum extent permitted by the law including but not limited to making other financial arrangements for indemnification regardless of whether or not the corporation would have the power to indemnify a person against such liability. The termination of any action, suit, or proceeding by judgment, order, settlement, conviction or upon a plea of nolo contendere or its equivalent shall not of itself create a presumption that the person did not act either in good faith, in a manner which he reasonably believed to be in the best interests of the corporation or that he did not have reasonable cause to believe that his conduct was lawful. Such determinations shall be made by the board of directors by a majority of a quorum consisting of directors who were not parties to such action, suit, or proceedings, or if such a quorum is not obtainable or even if obtainable a quorum of disinterested directors so directs, by independent legal counsel in a written opinion, or by the shareholders entitled to vote thereon. The indemnification or advancement of costs and expenses provided for by the corporation shall not be deemed exclusive of any other rights to which those indemnified may be entitled under the articles of incorporation, any bylaw, agreement, vote of shareholders or disinterested directors, or otherwise.

ARTICLE XII

Amendment of Articles of Incorporation

Unless otherwise provided for in these articles, the articles of incorporation of the corporation may be amended from time to time by a majority vote of all shareholders entitled to vote thereon, by written ballot in person or by proxy held at any general or special meeting of shareholders upon lawful notice.

ARTICLE XIII

Incorporator

The name and address of the incorporator is Joseph Daniluk, 4155 E. Jewell Ave. Suite 610 Denver, CO 80222.

IN WITNESS WHEREOF, the undersigned, Joseph Daniluk, for the purpose of forming a corporation under the laws of the State of Colorado, does make, file and record these articles of incorporation and certifies that the facts herein stated are true; and I have hereunto set my hand this 09 day of October, 2015.

INCORPORATOR:

Joseph Daniluk

**CERTIFICATE OF ACCEPTANCE
OF APPOINTMENT BY REGISTERED AGENT**

Joseph Daniluk hereby certifies his acceptance of appointment as Registered Agent for the above named corporation on this the 09 day of October, 2015.

Joseph Daniluk

LOCKING LINE BARRIERS CORPORATION dba LLB CORPORATION

MINUTES OF SPECIAL MEETING OF THE BOARD OF

DIRECTORS NOVEMBER 26, 2015

A special meeting of the board of Directors of Locking Line Barriers dba LLB Corporation was called on November 26, 2015. All Directors were present and waived notice of the meeting.

It was reported and moved that the Board of Directors approve and authorize the issuance of 11,000,000 shares of the 20,000,000 common shares authorized of the Capital Stock of the Corporation in accordance with the Corporate Resolution dated November 21, 2015 as follow:

8,500,000 Class A; unrestricted voting common shares,

And further;

2,500,000 Class B; restricted non-voting common shares,

A Total of 11,000,000 Capital Common Shares of the Corporation.

For the purposes of capitalizing the company and which the CEO shall be authorized to issue as necessary from time to time.

The motion was approved and resolved and thereby effective this date. There being no further business the meeting was adjourned.

/s/ *Joseph P.*

Daniluk Joseph P.

Daniluk, Director and

Secretary

EXHIBIT G TO FORM C

SAMPLE SUBSCRIPTION AGREEMENT

THIS INVESTMENT INVOLVES A HIGH DEGREE OF RISK. THIS INVESTMENT IS SUITABLE ONLY FOR PERSONS WHO CAN BEAR THE ECONOMIC RISK FOR AN INDEFINITE PERIOD OF TIME AND WHO CAN AFFORD TO LOSE THEIR ENTIRE INVESTMENT. FURTHERMORE, INVESTORS MUST UNDERSTAND THAT SUCH INVESTMENT IS ILLIQUID AND IS EXPECTED TO CONTINUE TO BE ILLIQUID FOR AN INDEFINITE PERIOD OF TIME. NO PUBLIC MARKET EXISTS FOR THE SECURITIES, AND NO PUBLIC MARKET IS EXPECTED TO DEVELOP FOLLOWING THIS OFFERING.

THE SECURITIES OFFERED HEREBY HAVE NOT BEEN REGISTERED UNDER THE SECURITIES ACT OF 1933, AS AMENDED (THE “SECURITIES ACT”), OR ANY STATE SECURITIES OR BLUE SKY LAWS AND ARE BEING OFFERED AND SOLD IN RELIANCE ON EXEMPTIONS FROM THE REGISTRATION REQUIREMENTS OF THE SECURITIES ACT AND STATE SECURITIES OR BLUE SKY LAWS. ALTHOUGH AN OFFERING STATEMENT HAS BEEN FILED WITH THE SECURITIES AND EXCHANGE COMMISSION (THE “SEC”), THAT OFFERING STATEMENT DOES NOT INCLUDE THE SAME INFORMATION THAT WOULD BE INCLUDED IN A REGISTRATION STATEMENT UNDER THE SECURITIES ACT AND IT IS NOT REVIEWED IN ANY WAY BY THE SEC. THE SECURITIES HAVE NOT BEEN APPROVED OR DISAPPROVED BY THE SEC, ANY STATE SECURITIES COMMISSION OR OTHER REGULATORY AUTHORITY, NOR HAVE ANY OF THE FOREGOING AUTHORITIES PASSED UPON THE MERITS OF THIS OFFERING OR THE ADEQUACY OR ACCURACY OF THE SUBSCRIPTION AGREEMENT OR ANY OTHER MATERIALS OR INFORMATION MADE AVAILABLE TO SUBSCRIBER IN CONNECTION WITH THIS OFFERING OVER THE WEB-BASED PLATFORM MAINTAINED BY TRUCROWD INC. (THE “INTERMEDIARY”). ANY REPRESENTATION TO THE CONTRARY IS UNLAWFUL.

INVESTORS ARE SUBJECT TO LIMITATIONS ON THE AMOUNT THEY MAY INVEST, AS SET OUT IN SECTION 4(d). THE COMPANY IS RELYING ON THE REPRESENTATIONS AND WARRANTIES SET FORTH BY EACH SUBSCRIBER IN THIS SUBSCRIPTION AGREEMENT AND THE OTHER INFORMATION PROVIDED BY SUBSCRIBER IN CONNECTION WITH THIS OFFERING TO DETERMINE THE APPLICABILITY TO THIS OFFERING OF EXEMPTIONS FROM THE REGISTRATION REQUIREMENTS OF THE SECURITIES ACT.

PROSPECTIVE INVESTORS MAY NOT TREAT THE CONTENTS OF THE SUBSCRIPTION AGREEMENT, THE OFFERING STATEMENT OR ANY OF THE OTHER MATERIALS AVAILABLE ON THE INTERMEDIARY’S WEBSITE (COLLECTIVELY, THE “OFFERING MATERIALS”) OR ANY COMMUNICATIONS FROM THE COMPANY OR ANY OF ITS OFFICERS, EMPLOYEES OR AGENTS AS INVESTMENT, LEGAL OR TAX ADVICE. IN MAKING AN INVESTMENT DECISION, INVESTORS MUST RELY ON THEIR OWN EXAMINATION OF THE COMPANY AND THE TERMS OF THIS OFFERING, INCLUDING THE MERITS AND THE RISKS INVOLVED. EACH PROSPECTIVE INVESTOR SHOULD CONSULT THE INVESTOR’S OWN COUNSEL, ACCOUNTANT AND OTHER PROFESSIONAL ADVISOR AS TO INVESTMENT, LEGAL, TAX AND OTHER RELATED MATTERS CONCERNING THE INVESTOR’S PROPOSED INVESTMENT.

THE OFFERING MATERIALS MAY CONTAIN FORWARD-LOOKING STATEMENTS AND INFORMATION RELATING TO, AMONG OTHER THINGS, THE COMPANY, ITS BUSINESS PLAN AND STRATEGY, AND ITS INDUSTRY. THESE FORWARD-LOOKING STATEMENTS ARE BASED ON THE BELIEFS OF, ASSUMPTIONS MADE BY, AND INFORMATION CURRENTLY AVAILABLE TO THE COMPANY’S MANAGEMENT. WHEN USED IN THE OFFERING MATERIALS, THE WORDS “ESTIMATE,” “PROJECT,” “BELIEVE,” “ANTICIPATE,” “INTEND,” “EXPECT” AND SIMILAR EXPRESSIONS ARE INTENDED TO IDENTIFY FORWARD-LOOKING STATEMENTS, WHICH CONSTITUTE FORWARD LOOKING STATEMENTS. THESE STATEMENTS REFLECT MANAGEMENT’S CURRENT VIEWS WITH RESPECT TO FUTURE EVENTS AND ARE SUBJECT TO RISKS AND UNCERTAINTIES THAT COULD CAUSE THE COMPANY’S ACTUAL RESULTS TO DIFFER MATERIALLY FROM

THOSE CONTAINED IN THE FORWARD-LOOKING STATEMENTS. INVESTORS ARE CAUTIONED NOT TO PLACE UNDUE RELIANCE ON THESE FORWARD-LOOKING STATEMENTS, WHICH SPEAK ONLY AS OF THE DATE ON WHICH THEY ARE MADE. THE COMPANY DOES NOT UNDERTAKE ANY OBLIGATION TO REVISE OR UPDATE THESE FORWARD-LOOKING STATEMENTS TO REFLECT EVENTS OR CIRCUMSTANCES AFTER SUCH DATE OR TO REFLECT THE OCCURRENCE OF UNANTICIPATED EVENTS.

THE INFORMATION PRESENTED IN THE OFFERING MATERIALS WAS PREPARED BY THE COMPANY SOLELY FOR THE USE BY PROSPECTIVE INVESTORS IN CONNECTION WITH THIS OFFERING. NO REPRESENTATIONS OR WARRANTIES ARE MADE AS TO THE ACCURACY OR COMPLETENESS OF THE INFORMATION CONTAINED IN ANY OFFERING MATERIALS, AND NOTHING CONTAINED IN THE OFFERING MATERIALS IS OR SHOULD BE RELIED UPON AS A PROMISE OR REPRESENTATION AS TO THE FUTURE PERFORMANCE OF THE COMPANY.

THE COMPANY RESERVES THE RIGHT IN ITS SOLE DISCRETION AND FOR ANY REASON WHATSOEVER TO MODIFY, AMEND AND/OR WITHDRAW ALL OR A PORTION OF THE OFFERING AND/OR ACCEPT OR REJECT IN WHOLE OR IN PART ANY PROSPECTIVE INVESTMENT IN THE SECURITIES OR TO ALLOT TO ANY PROSPECTIVE INVESTOR LESS THAN THE AMOUNT OF SECURITIES SUCH INVESTOR DESIRES TO PURCHASE. EXCEPT AS OTHERWISE INDICATED, THE OFFERING MATERIALS SPEAK AS OF THEIR DATE. NEITHER THE DELIVERY NOR THE PURCHASE OF THE SECURITIES SHALL, UNDER ANY CIRCUMSTANCES, CREATE ANY IMPLICATION THAT THERE HAS BEEN NO CHANGE IN THE AFFAIRS OF THE COMPANY SINCE THAT DATE.

The Company:

**Locking Line Barriers Corporation dba WaterBlocks
4155 E. Jewell Ave. Suite 610, Denver, CO 80222**

1. Subscription.

- a. The undersigned (“Subscriber”) hereby irrevocably subscribes for and agrees to purchase **Class B non-voting Common Stock** (singular - the “Security” or plural - the “Securities”), of:

2. **Locking Line Barriers Corporation dba WaterBlocks** (the “Company”),

at a purchase price of **\$2.00 per share** (the “Per Security Price”), upon the terms and conditions set forth herein. The rights of the Security are as set forth in **Offering Document** and any description of the Securities that appears in the Offering Materials is qualified in its entirety by such document.

- a. By executing this Subscription Agreement, Subscriber acknowledges that Subscriber has received this Subscription Agreement, a copy of the Offering Statement of the Company filed with the SEC and any other information required by the Subscriber to make an investment decision.
- b. This Subscription may be accepted or rejected in whole or in part, at any time prior to a Closing Date (as hereinafter defined), by the Company at its sole discretion. In addition, the Company, at its sole discretion, may allocate to Subscriber only a portion of the number of Securities Subscriber has subscribed for. The Company will notify Subscriber whether this subscription is accepted (whether in whole or in part) or rejected. If Subscriber’s subscription is rejected, Subscriber’s payment (or portion thereof if partially rejected) will be returned to Subscriber without interest and all of Subscriber’s obligations hereunder shall terminate.

- c. The aggregate number of Securities sold shall not exceed the Maximum Number of Units, as set in the Form C filed in relation to this offering with the SEC (the “Oversubscription Offering”). The Company may accept subscriptions until the “Termination Date” as set in the Form C filed with the SEC in relation to this offering. Providing that subscriptions equaling or exceeding the “Minimum Offering” as set forth in the Form C filed with the SEC, the Company may elect at any time to close all or any portion of this offering, on various dates at or prior to the Termination Date (each a “Closing Date”).
- d. In the event of rejection of this subscription in its entirety, or in the event the sale of the Securities (or any portion thereof) is not consummated for any reason, this Subscription Agreement shall have no force or effect.
- e. The terms of this Subscription Agreement shall be binding upon Subscriber and its transferees, heirs, successors and assigns (collectively, “Transferees”); provided that for any such transfer to be deemed effective, the Transferee shall have executed and delivered to the Company in advance an instrument in a form acceptable to the Company in its sole discretion, pursuant to which the proposed Transferee shall be acknowledge, agree, and be bound by the representations and warranties of Subscriber, terms of this Subscription Agreement.

Purchase Procedure.

- a. **Payment.** The purchase price for the Securities shall be paid simultaneously with the execution and delivery to the Company of the signature page of this Subscription Agreement, which signature and delivery may take place through digital online means. Subscriber shall deliver a signed copy of this Subscription Agreement along with payment for the aggregate purchase price of the Securities by cash, credit cards, ACH electronic transfer or wire transfer to an account designated by the Company, or by any combination of such methods.
- b. **Escrow arrangements.** Payment for the Securities shall be received by Prime Trust, LLC (the “Escrow Agent”) from the undersigned by transfer of immediately available funds, check or other means approved by the Company at least two days prior to the applicable Closing Date, in the amount as set forth in Appendix A on the signature page hereto and otherwise in accordance with Intermediary’s payment processing instructions. Upon such Closing, the Escrow Agent shall release such funds to the Company. The undersigned shall receive notice and evidence of the digital entry of the number of the Securities owned by undersigned reflected on the books and records of the Company and verified by the “Transfer Agent” designated by the Company, which books and records shall bear a notation that the Securities were sold in reliance upon Regulation CF.

3. **Representations and Warranties of the Company.**

The Company represents and warrants to Subscriber that the following representations and warranties are true and complete in all material respects as of the date of each Closing Date, except as otherwise indicated. For purposes of this Agreement, an individual shall be deemed to have “knowledge” of a particular fact or other matter if such individual is actually aware of such fact. The Company will be deemed to have “knowledge” of a particular fact or other matter if one of the Company’s current officers has, or at any time had, actual knowledge of such fact or other matter.

- a. **Organization and Standing.** The Company is a “C” CORPORATION) duly formed, validly existing and in good standing under the laws of the State of Colorado. The Company has all requisite power and authority to own and operate its properties and assets, to execute and deliver this Subscription Agreement, and any other agreements or instruments required hereunder. The Company is duly qualified and is authorized to do business and is in good standing as a foreign corporation in all jurisdictions in which the nature of its activities and of its properties (both

- owned and leased) makes such qualification necessary, except for those jurisdictions in which failure to do so would not have a material adverse effect on the Company or its business.
- b. Eligibility of the Company to Make an Offering under Section 4(a)(6). The Company is eligible to make an offering under Section 4(a)(6) of the Securities Act and the rules promulgated thereunder by the SEC.
 - c. Issuance of the Securities. The issuance, sale and delivery of the Securities in accordance with this Subscription Agreement has been duly authorized by all necessary corporate action on the part of the Company. The Securities, when so issued, sold and delivered against payment therefor in accordance with the provisions of this Subscription Agreement, will be duly and validly issued, fully paid and non-assessable. The Shares purchased are Digital Shares held for the by the Corporate Transfer Agent, Colonial Stock Transfer, Company, Inc., for the benefit of the purchaser, and printed certificate(s) are available from the Transfer Agent upon request at the purchaser's expense.
 - d. Authority for Agreement. The execution and delivery by the Company of this Subscription Agreement and the consummation of the transactions contemplated hereby (including the issuance, sale and delivery of the Securities) are within the Company's powers and have been duly authorized by all necessary corporate action on the part of the Company. Upon full execution hereof, this Subscription Agreement shall constitute a valid and binding agreement of the Company, enforceable against the Company in accordance with its terms, except (i) as limited by applicable bankruptcy, insolvency, reorganization, moratorium, and other laws of general application affecting enforcement of creditors' rights generally, (ii) as limited by laws relating to the availability of specific performance, injunctive relief, or other equitable remedies and (iii) with respect to provisions relating to indemnification and contribution, as limited by considerations of public policy and by federal or state securities laws.
 - e. No filings. Assuming the accuracy of the Subscriber's representations and warranties set forth in Section 4 hereof, no order, license, consent, authorization or approval of, or exemption by, or action by or in respect of, or notice to, or filing or registration with, any governmental body, agency or official is required by or with respect to the Company in connection with the execution, delivery and performance by the Company of this Subscription Agreement except (i) for such filings as may be required under Section 4(a)(6) of the Securities Act or the rules promulgated thereunder or under any applicable state securities laws, (ii) for such other filings and approvals as have been made or obtained, or (iii) where the failure to obtain any such order, license, consent, authorization, approval or exemption or give any such notice or make any filing or registration would not have a material adverse effect on the ability of the Company to perform its obligations hereunder.
 - f. Financial statements. Complete copies of the Company's consolidated financial statements (the "Financial Statements") have been made available to the Subscriber and appear in the Offering Circular. The Financial Statements are based on the books and records of the Company and fairly present in all material respects the consolidated financial condition of the Company as of the respective dates they were prepared and the results of the operations and cash flows of the Company for the periods indicated. The Financial Statements comply with the requirements of Rule 201 of Regulation Crowdfunding, as promulgated by the SEC.
 - g. Proceeds. The Company shall use the proceeds from the issuance and sale of the Securities as set forth in the Offering Materials.
 - h. Litigation. Except as set forth in the Offering Statement, there is no pending action, suit, proceeding, arbitration, mediation, complaint, claim, charge or investigation before any court, arbitrator, mediator or governmental body, or to the Company's knowledge, currently threatened in writing (a) against the Company or (b) against any consultant, officer, manager, director or key employee of the Company arising out of his or her consulting, employment or board relationship with the Company or that could otherwise materially impact the Company.
4. Representations and Warranties of Subscriber. By executing this Subscription Agreement, Subscriber (and, if Subscriber is purchasing the Securities subscribed for hereby in a fiduciary capacity,

the person or persons for whom Subscriber is so purchasing) represents and warrants, which representations and warranties are true and complete in all material respects as of the date of the Subscriber's respective Closing Date(s):

- a. Requisite Power and Authority. Such Subscriber has all necessary power and authority under all applicable provisions of law to execute and deliver this Subscription Agreement and other agreements required hereunder and to carry out their provisions. All action on Subscriber's part required for the lawful execution and delivery of this Subscription Agreement and other agreements required hereunder have been or will be effectively taken prior to the Closing Date. Upon their execution and delivery, this Subscription Agreement and other agreements required hereunder will be valid and binding obligations of Subscriber, enforceable in accordance with their terms, except (a) as limited by applicable bankruptcy, insolvency, reorganization, moratorium or other laws of general application affecting enforcement of creditors' rights and (b) as limited by general principles of equity that restrict the availability of equitable remedies.
- b. Investment Representations. Subscriber understands that the Securities have not been registered under the Securities Act of 1933, as amended (the "Securities Act"). Subscriber also understands that the Securities are being offered and sold pursuant to an exemption from registration contained in the Act based in part upon Subscriber's representations contained in this Subscription Agreement.
- c. Illiquidity and Continued Economic Risk. Subscriber acknowledges and agrees that there is no ready public market for the Securities and that there is no guarantee that a market for their resale will ever exist. Subscriber must bear the economic risk of this investment indefinitely and the Company has no obligation to list the Securities on any market or take any steps (including registration under the Securities Act or the Securities Exchange Act of 1934, as amended) with respect to facilitating trading or resale of the Securities. Subscriber acknowledges that Subscriber is able to bear the economic risk of losing Subscriber's entire investment in the Securities. Subscriber also understands that an investment in the Company involves significant risks and has taken full cognizance of and understands all of the risk factors relating to the purchase of Securities.
- d. Resales. Subscriber agrees that during the one-year period beginning on the date on which it acquired Securities pursuant to this Subscription Agreement, it shall not transfer such Securities except:
 - i. To the Company;
 - ii. To an "accredited investor" within the meaning of Rule 501 of Regulation D under the Securities Act;
 - iii. As part of an offering registered under the Securities Act with the SEC; or
 - iv. To a member of the Subscriber's family or the equivalent, to a trust controlled by the Subscriber, to a trust created for the benefit of a member of the family of the Subscriber or equivalent, or in connection with the death or divorce of the Subscriber or other similar circumstance.
- e. Investment Limits. Subscriber represents that either:
 - i. Either of Subscriber's net worth or annual income is less than \$107,000, and that the amount it is investing pursuant to this Subscription Agreement, together with all other amounts invested in offerings under Section 4(a)(6) of the Securities Act within the previous 12 months, is either less than (A) 5% of the lower of its annual income or net worth, or (B) \$2,200; or
 - ii. Both of Subscriber's net worth and annual income are more than \$107,000, and that the amount it is investing pursuant to this Subscription Agreement, together with all other amounts invested in offerings under Section 4(a)(6) of the Securities Act within the previous 12 months, is less than 10% of the lower of its annual income or net worth, and does not exceed \$107,000.
- f. Shareholder information. Within five days after receipt of a request from the Company, the Subscriber hereby agrees to provide such information with respect to its status as a shareholder

(or potential shareholder) and to execute and deliver such documents as may reasonably be necessary to comply with any and all laws and regulations to which the Company is or may become subject. **Subscriber further agrees that in the event it transfers any Securities, it will require the transferee of such Securities to agree to provide such information to the Company as a condition of such transfer.**

- g. Company Information. Subscriber has read the Offering Statement. Subscriber understands that the Company is subject to all the risks that apply to early-stage companies, whether or not those risks are explicitly set out in the Offering Circular. Subscriber has had an opportunity to discuss the Company's business, management and financial affairs with managers, officers and management of the Company and has had the opportunity to review the Company's operations and facilities. Subscriber has also had the opportunity to ask questions of and receive answers from the Company and its management regarding the terms and conditions of this investment. Subscriber acknowledges that except as set forth herein, no representations or warranties have been made to Subscriber, or to Subscriber's advisors or representative, by the Company or others with respect to the business or prospects of the Company or its financial condition.
- h. Valuation. The Subscriber acknowledges that the price of the Securities was set by the Company on the basis of the Company's internal valuation and no warranties are made as to value. The Subscriber further acknowledges that future offerings of Securities may be made at lower valuations, with the result that the Subscriber's investment will bear a lower valuation.
- i. Domicile. Subscriber maintains Subscriber's domicile (and is not a transient or temporary resident) at the address shown on the signature page.
- j. Foreign Investors. If Subscriber is not a United States person (as defined by Section 7701(a)(30) of the Internal Revenue Code of 1986, as amended), Subscriber hereby represents that it has satisfied itself as to the full observance of the laws of its jurisdiction in connection with any invitation to subscribe for the Securities or any use of this Subscription Agreement, including (i) the legal requirements within its jurisdiction for the purchase of the Securities, (ii) any foreign exchange restrictions applicable to such purchase, (iii) any governmental or other consents that may need to be obtained, and (iv) the income tax and other tax consequences, if any, that may be relevant to the purchase, holding, redemption, sale, or transfer of the Securities. Subscriber's subscription and payment for and continued beneficial ownership of the Securities will not violate any applicable securities or other laws of the Subscriber's jurisdiction.

5. Revisions to Manner of Holding.

In the event that statutory or regulatory changes are adopted such that it becomes possible for companies whose purpose is limited to acquiring, holding and disposing of securities issued by a single company ("Crowdfunding SPVs") to make offerings under Section 4(a)(6) of the Securities Act, Subscriber agrees to exchange the Securities for securities issued by a Crowdfunding SPV in a transaction complying with the requirements of Section 3(a)(9) of the Securities Act. Subscriber agrees that in the event the Subscriber does not provide information sufficient to effect such exchange in a timely manner, the Company may repurchase the Securities at a price to be determined by the Board of Directors. Subscriber further agrees to transfer its holdings of securities issued under Section 4(a)(6) into "street name" in a brokerage account in Subscriber's name, provided that the Company pay all costs of such transfer. Subscriber agrees that in the event the Subscriber does not provide information sufficient to effect such transfer in a timely manner, the Company may repurchase the Securities at a price to be determined by the Board of Directors.

6. Indemnity. The representations, warranties and covenants made by the Subscriber herein shall survive the closing of this Agreement. The Subscriber agrees to indemnify and hold harmless the Company and its respective officers, directors and affiliates, and each other person, if any, who controls the Company within the meaning of Section 15 of the Securities Act against any and all loss, liability, claim, damage and expense whatsoever (including, but not limited to, any and all reasonable attorneys' fees, including attorneys' fees on appeal) and expenses reasonably incurred in investigating, preparing or defending against any false representation or warranty or breach of failure by the Subscriber to comply with any covenant or agreement made by the Subscriber herein or in any other document furnished by

the Subscriber to any of the foregoing in connection with this transaction.

7. Governing Law; Jurisdiction. This Subscription Agreement shall be governed and construed in accordance with the laws of the State of **Colorado**.

EACH OF THE SUBSCRIBER AND THE COMPANY CONSENTS TO THE JURISDICTION OF ANY STATE OR FEDERAL COURT OF COMPETENT JURISDICTION LOCATED WITHIN THE STATE AND NO OTHER PLACE AND IRREVOCABLY AGREES THAT ALL ACTIONS OR PROCEEDINGS RELATING TO THIS SUBSCRIPTION AGREEMENT MAY BE LITIGATED IN SUCH COURTS. EACH OF SUBSCRIBER AND THE COMPANY ACCEPTS FOR ITSELF AND HIMSELF AND IN CONNECTION WITH ITS AND HIS RESPECTIVE PROPERTIES, GENERALLY AND UNCONDITIONALLY, THE EXCLUSIVE JURISDICTION OF THE AFORESAID COURTS AND WAIVES ANY DEFENSE OF FORUM NON CONVENIENS, AND IRREVOCABLY AGREES TO BE BOUND BY ANY JUDGMENT RENDERED THEREBY IN CONNECTION WITH THIS SUBSCRIPTION AGREEMENT. EACH OF SUBSCRIBERS AND THE COMPANY FURTHER IRREVOCABLY CONSENTS TO THE SERVICE OF PROCESS OUT OF ANY OF THE AFOREMENTIONED COURTS IN THE MANNER AND IN THE ADDRESS SPECIFIED IN SECTION 9 AND THE SIGNATURE PAGE OF THIS SUBSCRIPTION AGREEMENT. HOWEVER, NOTHING IN THIS PARAGRAPH SHALL BE CONSTRUED TO BE APPLICABLE TO ANY ACTION ARISING UNDER THE FEDERAL SECURITIES LAWS.

EACH OF THE PARTIES HERETO HEREBY IRREVOCABLY WAIVES ALL RIGHT TO TRIAL BY JURY IN ANY ACTION, PROCEEDING OR COUNTERCLAIM (WHETHER BASED IN CONTRACT, TORT OR OTHERWISE) ARISING OUT OF OR RELATING TO THIS SUBSCRIPTION AGREEMENT OR THE ACTIONS OF EITHER PARTY IN THE NEGOTIATION, ADMINISTRATION, PERFORMANCE AND ENFORCEMENT THEREOF, EACH OF THE PARTIES HERETO ALSO WAIVES ANY BOND OR SURETY OR SECURITY UPON SUCH BOND WHICH MIGHT, BUT FOR THIS WAIVER, BE REQUIRED OF SUCH PARTY. EACH OF THE PARTIES HERETO FURTHER WARRANTS AND REPRESENTS THAT IT HAS REVIEWED THIS WAIVER WITH ITS LEGAL COUNSEL, AND THAT IT KNOWINGLY AND VOLUNTARILY WAIVES ITS JURY TRIAL RIGHTS FOLLOWING CONSULTATION WITH LEGAL COUNSEL. THIS WAIVER IS IRREVOCABLE, MEANING THAT IT MAY NOT BE MODIFIED EITHER ORALLY OR IN WRITING, AND THIS WAIVER SHALL APPLY TO ANY SUBSEQUENT AMENDMENTS, RENEWALS, SUPPLEMENTS OR MODIFICATIONS TO THIS SUBSCRIPTION AGREEMENT. IN THE EVENT OF LITIGATION, THIS SUBSCRIPTION AGREEMENT MAY BE FILED AS A WRITTEN CONSENT TO A TRIAL BY THE COURT. BY AGREEING TO THIS PROVISION, EACH SUBSCRIBER WILL NOT BE DEEMED TO HAVE WAIVED THE COMPANY'S COMPLIANCE WITH U.S. FEDERAL SECURITIES LAWS AND THE RULES AND REGULATIONS PROMULGATED THEREUNDER.

8. Notices. Notice, requests, demands and other communications relating to this Subscription Agreement and the transactions contemplated herein shall be in writing and shall be deemed to have been duly given if and when (a) delivered personally, on the date of such delivery; or (b) mailed by registered or certified mail, postage prepaid, return receipt requested, in the third day after the posting thereof; or (c) emailed, telecopied or cabled, on the date of such delivery to the address of the respective parties as follows:

If to the Company, to:

**PHYSICAL: Locking Line Barriers Corporation dba WaterBlocks
4155 E. Jewell Ave. Suite 610, Denver, CO 80222**

DIGITAL: Info@WaterBlocks.net

Attn: Shareholder Services

If to a Subscriber:

to Subscriber's address as shown on the signature page hereto

or to such other address as may be specified by written notice from time to time by the party entitled to receive such notice. Any notices, requests, demands or other communications by telecopy or cable shall be confirmed by letter given in accordance with (a) or (b) above.

9. Miscellaneous.

- a. All pronouns and any variations thereof shall be deemed to refer to the masculine, feminine, neuter, singular or plural, as the identity of the person or persons or entity or entities may require.
- b. This Subscription Agreement is not transferable or assignable by Subscriber.
- c. The representations, warranties and agreements contained herein shall be deemed to be made by and be binding upon Subscriber and its heirs, executors, administrators and successors and shall inure to the benefit of the Company and its successors and assigns.
- d. None of the provisions of this Subscription Agreement may be waived, changed or terminated orally or otherwise, except as specifically set forth herein or except by a writing signed by the Company and Subscriber.
- e. In the event any part of this Subscription Agreement is found to be void or unenforceable, the remaining provisions are intended to be separable and binding with the same effect as if the void or unenforceable part were never the subject of agreement.
- f. The invalidity, illegality or unenforceability of one or more of the provisions of this Subscription Agreement in any jurisdiction shall not affect the validity, legality or enforceability of the remainder of this Subscription Agreement in such jurisdiction or the validity, legality or enforceability of this Subscription Agreement, including any such provision, in any other jurisdiction, it being intended that all rights and obligations of the parties hereunder shall be enforceable to the fullest extent permitted by law.
- g. This Subscription Agreement supersedes all prior discussions and agreements between the parties with respect to the subject matter hereof and contains the sole and entire agreement between the parties hereto with respect to the subject matter hereof.
- h. The terms and provisions of this Subscription Agreement are intended solely for the benefit of each party hereto and their respective successors and assigns, and it is not the intention of the parties to confer, and no provision hereof shall confer, third-party beneficiary rights upon any other person.
- i. The headings used in this Subscription Agreement have been inserted for convenience of reference only and do not define or limit the provisions hereof.
- j. This Subscription Agreement may be executed in any number of counterparts, each of which will be deemed an original, but all of which together will constitute one and the same instrument.
- k. If any recapitalization or other transaction affecting the stock of the Company is effected, then any new, substituted or additional securities or other property which is distributed with respect to the Securities shall be immediately subject to this Subscription Agreement, to the same extent that the Securities, immediately prior thereto, shall have been covered by this Subscription Agreement.
- l. No failure or delay by any party in exercising any right, power or privilege under this Subscription Agreement shall operate as a waiver thereof nor shall any single or partial exercise thereof preclude any other or further exercise thereof or the exercise of any other right, power or privilege. The rights and remedies herein provided shall be cumulative and not exclusive of any rights or remedies provided by law.

[SIGNATURE PAGE FOLLOWS]

SUBSCRIPTION AGREEMENT SIGNATURE PAGE

The undersigned, desiring to purchase **the Security**, “Class B non-voting Common Stock Shares” of the Company. by executing this signature page, hereby executes, adopts and agrees to all terms, conditions and representations of the Subscription Agreement.

(a) The undersigned hereby subscribes for %%UNIT_COUNT%% Class B non-voting Common Stock Shares

(b) The undersigned hereby irrevocably subscribes for the number of shares stated above at the purchase price of \$2.00 per Share for the aggregate purchase price of: %%AMOUNT%%

(c) The Securities being subscribed for will be owned by, and should be recorded on the Company’s books as held in the name of:

Investor Signature:

%%INVESTOR_NAME%%

(print name of owner or joint owners)

%%INVESTOR_SIGNATURES%%

Company Signature:

This Subscription is accepted on %%EXECUTION_TIME_LEGAL%%

By: Locking Line Barriers Corporation dba WaterBlocks